

Product brochure

Disconnectors and earthing switches

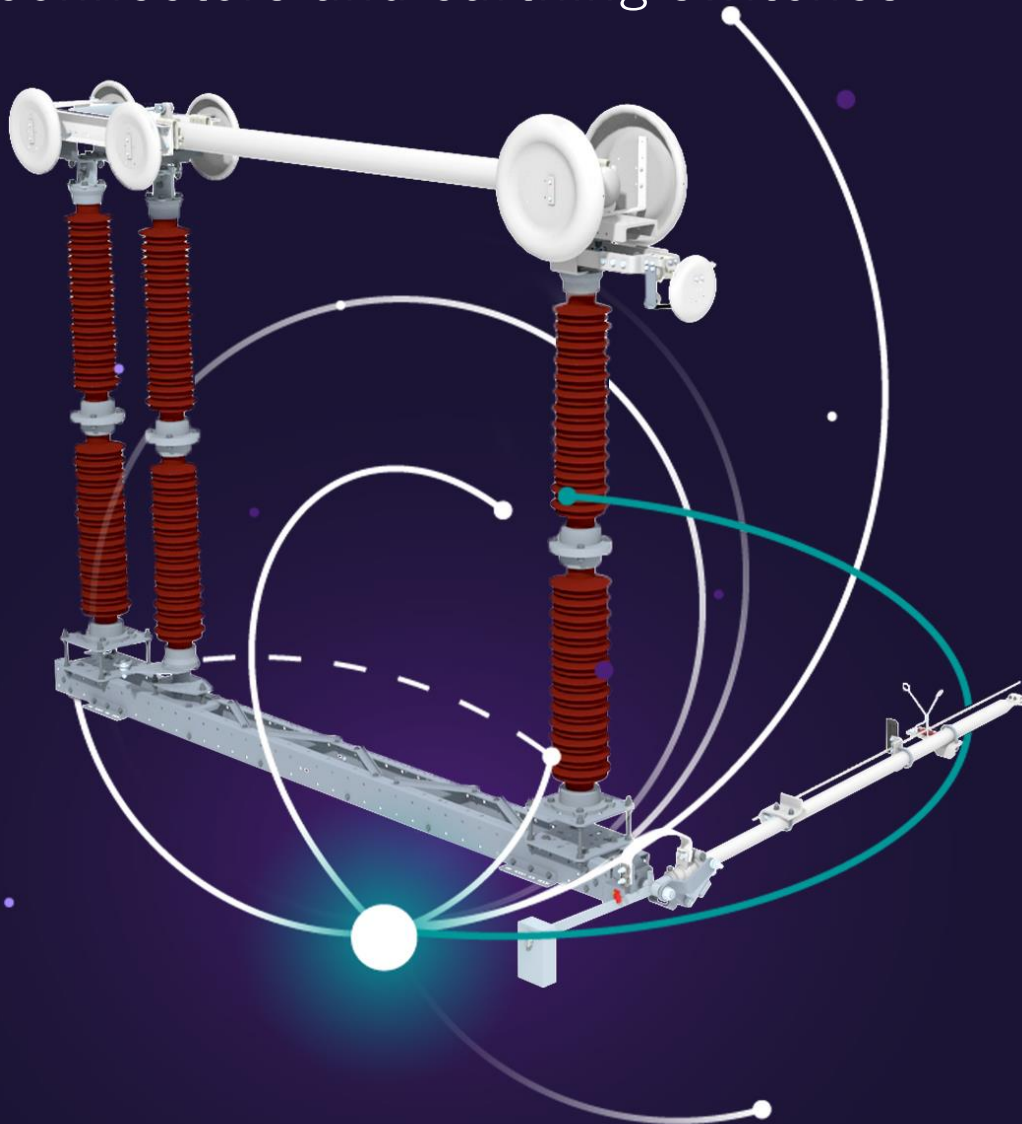

01	About Siemens Energy Page 3	09	DAL disconnecter Page 11
02	Our experience and performance Page 3	10	RDA disconnecter Page 13
03	Our products strengths Page 4	11	BC disconnecter Page 15
04	Voltage range Page 5	12	EVR disconnecter Page 17
05	Contact system Page 7	13	LAV disconnecter Page 19
06	Arc restrictors Page 7	14	LAH disconnecter Page 21
07	3DV8 command Page 8	15	GTF earthing switch Page 23
08	EVL disconnecter Page 9	16	TC earthing switch Page 25



About Siemens Energy

The Siemens Energy has a business unit specialized in high voltage disconnectors and earthing switches manufacturing for open air substations.

Through personalized service, we offer to our customers optimized solutions both technically and economically, developed from an extensive high voltage disconnectors portfolio and associated services.

Our products have passed the most rigorous tests and their quality is assured by ISO 9001, factors that guarantee its full functionality along decades. This is still proven given the varied applications already installed and fully functioning in Brazil and worldwide.

Our experience and performance

Siemens Energy is the main producer of disconnectors and high voltages earthing switches in Brazil, counting on the experience of more than 80 years, inherited from SIEMENS.

Our factories have the most modern production technologies, factor that added with a high skilled and capacitated team assure the quality and safety of our products. At the same time, in according to the global sustainability commitment, the processes developed by the SIEMENS ENERGY match high productivity and sustainability, being completely aligned with the high SIEMENS brand.



And when the topic is performance, Siemens Energy disconnectors keep operational in Brazil and over the World. Our portfolio is filled with solutions capable to operate under extreme environment conditions. We have designed applications that can work under seismic tremors, ice loads up to 20 mm and temperatures that range from -50 °C to 50 °C.

Our product strengths



Subsets already assembled and presets from factory



For each disconnector, the moving part of main blade is individually tested.



Easy assemble and commissioning on substation site: The assemble of our products is intuitive and has an instruction manual.



Silver made contacts: a high conductive material and self lubrication, demanding less maintenance.







Our technical assistance is permanent and agile, assuring the best solution for any problem.



Our technical support is for all disconnector service life.

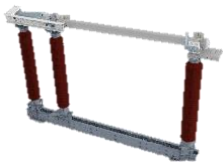

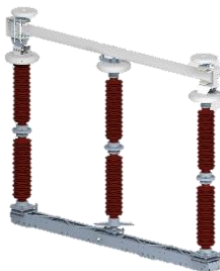
Our products can be **recycled** by the end of its service life.

Voltage (kV)	Current (A)				
		EVL	DAL	RDA	BC
72,5	I_n	3150	3150	3150	3150
	I_s				
	$I_t (1s)$		40		
	$I_n(3s)$				
145	I_n	3150	3150	4000	3150
	I_s				
	$I_t (1s)$		40		
	$I_n(3s)$				
245	I_n	5000	3150	4000	3150
	I_s				
	$I_t (1s)$		40		
	$I_n(3s)$				
362	I_n			4000	
	I_s				
	$I_t (1s)$				
	$I_n(3s)$				
550	I_n				
	I_s				
	$I_t (1s)$				
	$I_n(3s)$				
880	I_n				
	I_s				
	$I_t (1s)$				
	$I_n(3s)$				

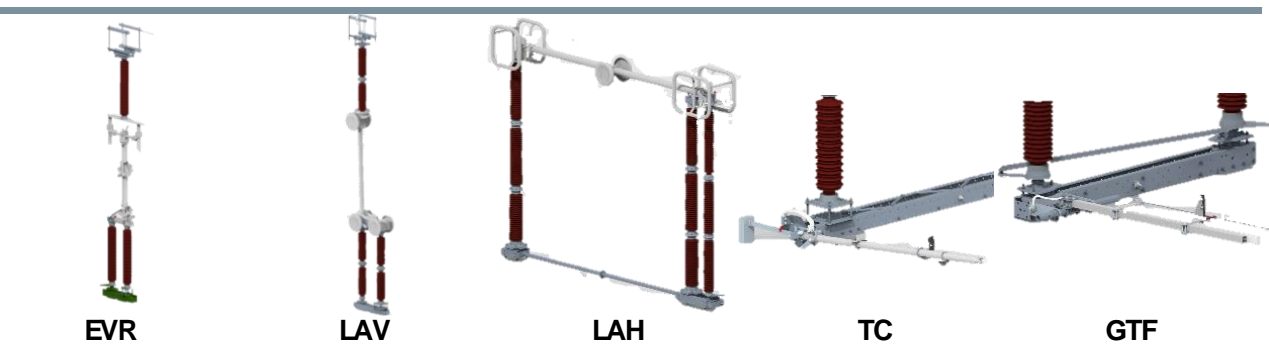

EVR	LAV	LAH	TC	GTF
3150			Not aplicable	Not aplicable
3150	4000			
3150	4000	3150		
	3150	3150		
	5000	5000		
	4000			

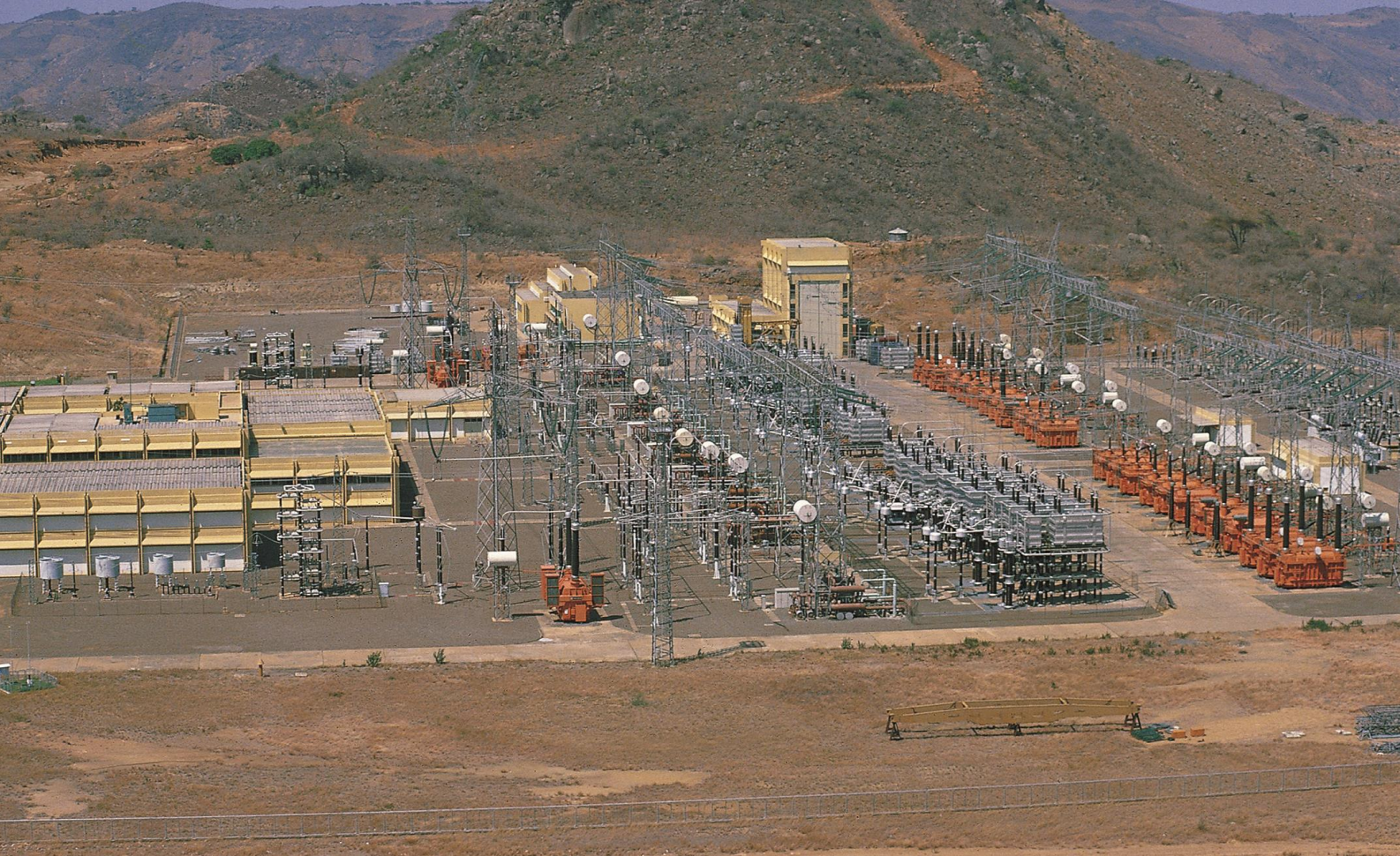

Contact system

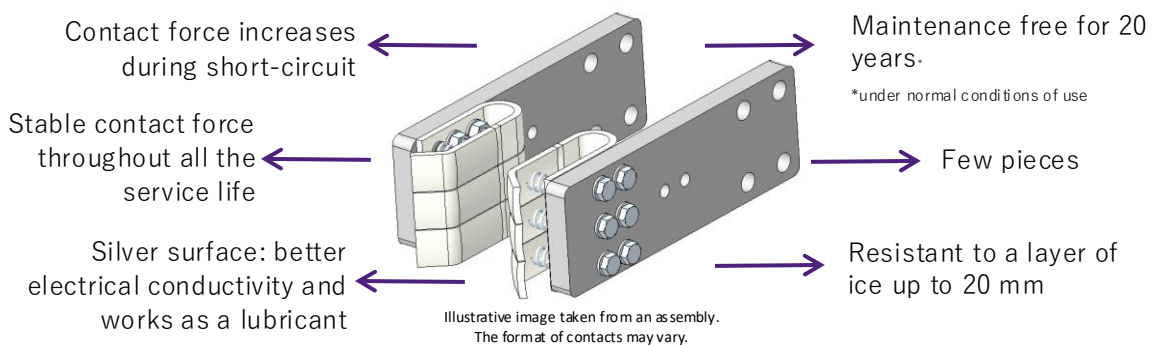

Arc restrictors

Arc restrictors can be supplied for all types of Siemens Energy disconnectors. With this accessory, disconnectors are capable to maneuver the induced currents during busbar transferences. During the switching operation from bus 1 to bus 2, the existing potential difference causes an electrical arc between the disconnector contacts.

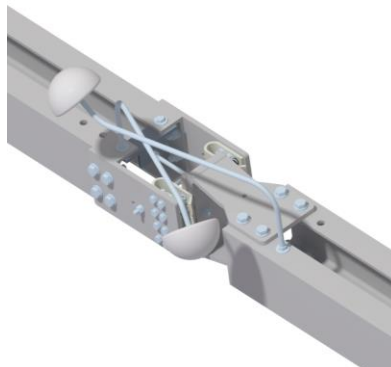

The B annex of the IEC 62271-102 describe the maneuver loads that appears under a busbar transference without interruption. Our arc restrictors for bars transfer has type tests with more then 100 operational cycles of establishment and interruption of current.



3DV8 Command

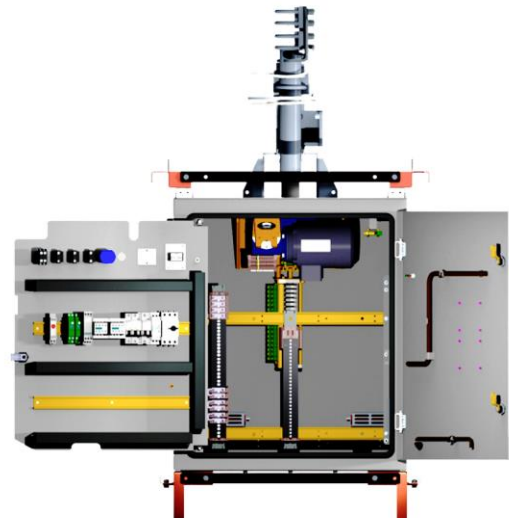

Besides, it assures wide space for cables and connections, also having protection against condensation. Easy to use, it can also be safely manually operated.

Easy to assemble and to do maintenance, our exclusive 3DV8 command demands revision only after 1000 maneuvers.

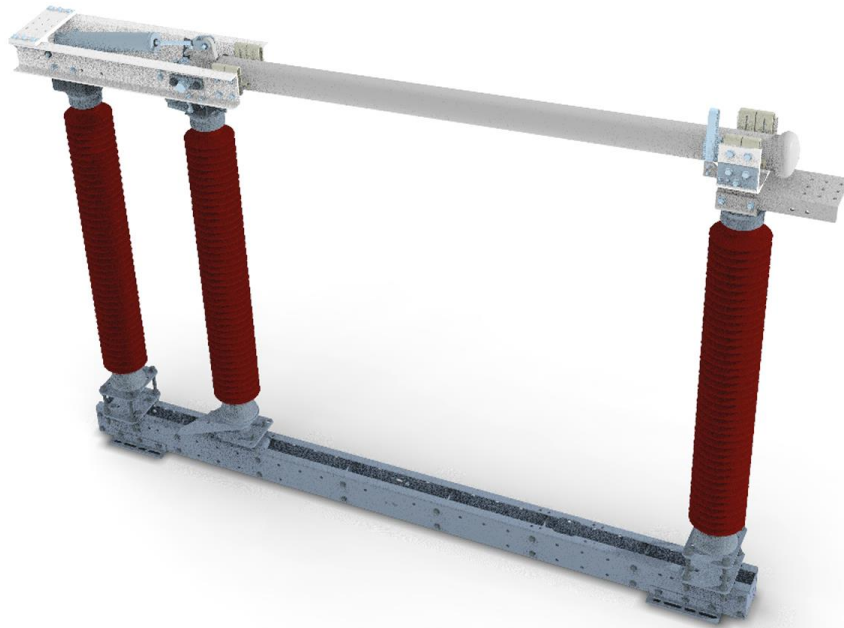

EVL disconnecter

Vertical Opening – EVL:

Disconnecter is constituted by three insulating columns, where two of them are fixed (support the fixed contacts) and one rotative (which moves the movable contacts).

Main Characteristics



Due to its vertical opening, the disconnecter allows a small distance between phases.



The locking system with double kinematics assures an excellent contact even with over 50kA short-circuit.



Designed lifetime for over 30 years.

Available attachments Earthing switch

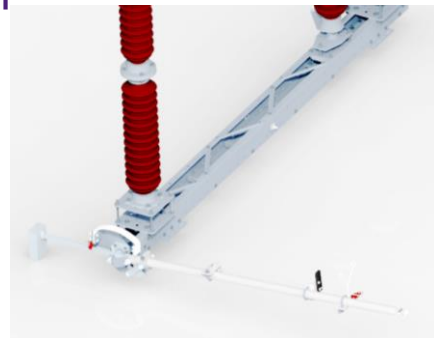

Bus transfer

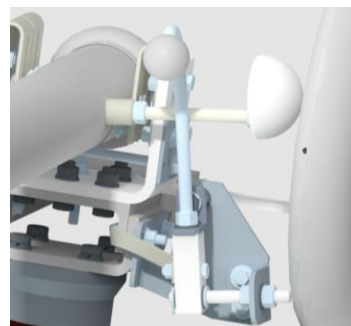

Adaptable to customers needs

The disconnecter arrange can be side by side or aligned. It is also possible to adapt for higher nominal and short-circuit currents. Furthermore, the modular design allows future installations of the available attachments.

Mounting bases



Each pole from the EVL disconnecter is mounted over a galvanized steel base. The bases are compact and designed to support high mechanical loads. High quality bearings are used, which are maintenance and lubrication free.



The product package is optimized developed, reaffirming the Siemens Energy compromise with the preservation of the natural resources.

Contact system

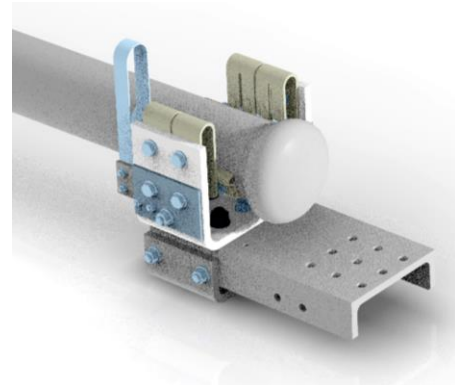

The EVL disconnecter contact occurs by a double kinematics system which assures more safety at the contact. During the closing, the first movement approach the contacts and the second lock them. The description of the movement is: after the first movement is done, the contact force is generated by the blade rotation around its own axis, only then, the blade is locked. This system requires low torques, which makes the movement smoother.

Voltage range (kV)	Atmospheric impulse withstand voltage (kV)	Nominal current (A)	Withstand current of short duration - 1s (kA)	Peak current (kA)
72,5	350	Up to 3150	50	130
145	550-650	Up to 3150	50	130
245	950-1150	Up to 3150	50	130
550	1550-1800	Up to 5000	63	160

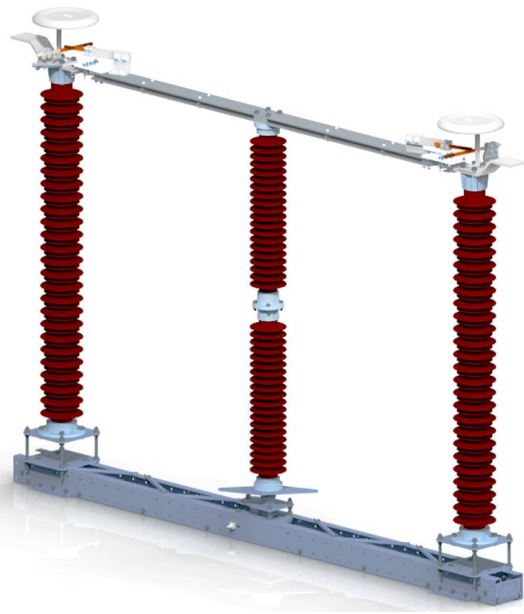

DAL disconnector

Double lateral opening – DAL:

It is constituted by three insulating columns, being two lateral fixed and one rotative at the center. The central one supports the main blade, and the lateral ones supports the fixed contacts.

Main Characteristics



Ideal for applications in substations where the space between phases is limited.



Contact system built with few components, offering low electrical resistance during maneuvers.



Designed lifetime for over 30 years.

Available attachments

Earthing switch

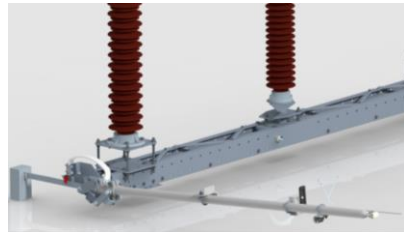

Bus transfer

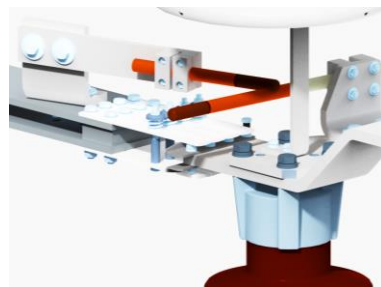

Adaptable to customers needs

The disconnector arrange can be side by side or aligned. It is also possible to adapt for higher nominal and short-circuit currents. Furthermore, the modular design allows future installations of the available attachments.

Mounting bases



Each pole from the DAL disconnecter is mounted over a galvanized steel base. The bases are compact and designed to support high mechanical loads. High quality bearings are used, which are maintenance and lubrication free.



The product package is optimized developed, reaffirming the Siemens Energy compromise with the preservation of the natural resources.

Contact system

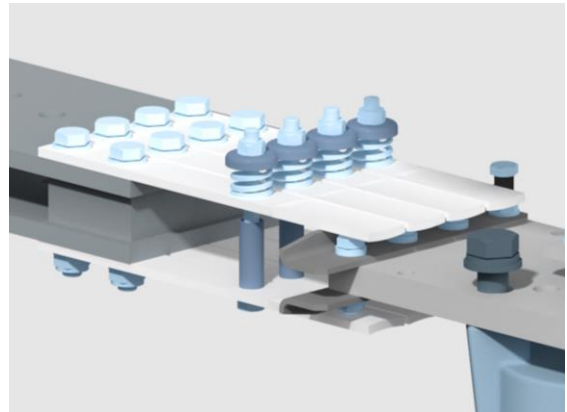

The DAL disconnecter main contact system is constituted by a pair of contact fingers in each side of the main blade and the bus transfer is fixed directly at the terminal.

Voltage range (kV)	Atmospheric impulse withstand voltage (kV)	Nominal current (A)	Withstand current of short duration - 1s (kA)	Peak current (kA)
72,5	350	Up to 3150	40	130
145	650	Up to 3150	40	130
245	950-1050	Up to 3150	40	130

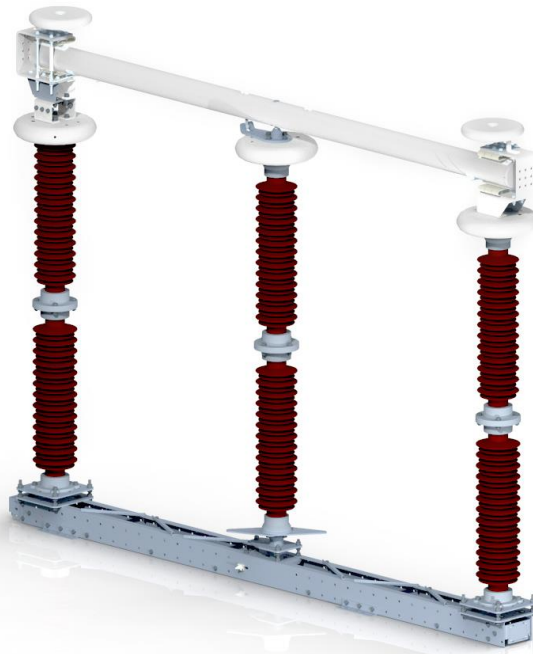

RDA disconnecter

Double lateral opening – RDA:

It is constituted by three insulating columns, being two lateral fixed and one rotative at the center.

Main Characteristics



Ideal for applications in substations where the vertical space between phases is limited.



Main blade built with steel tubes (greater robustness of the living part).



Contact system with double kinematics.



High operating interval before decommissioning.

Adaptable to customers needs

The disconnecter arrange can be side by side or aligned. It is also possible to adapt for higher nominal and short-circuit currents. Furthermore, the modular design allows future installations of the available attachments.

Available attachments

Earthing switch

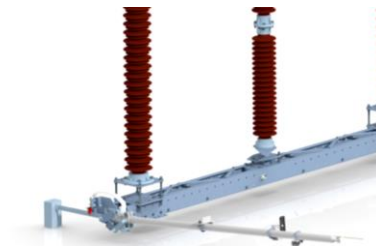

Bus transfer

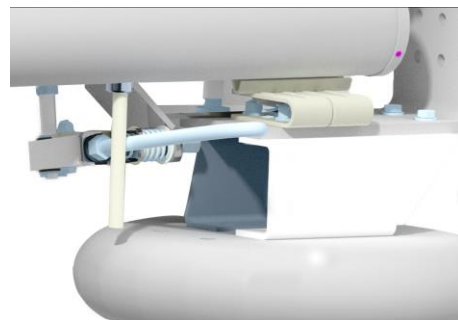

Mounting bases



Each pole from the RDA disconnecter is mounted over a galvanized steel base. The bases are compact and designed to support high mechanical loads. High quality bearings are used, which are maintenance and lubrication free.



The product package is optimized developed, reaffirming the Siemens Energy compromise with the preservation of the natural resources.

Contact system

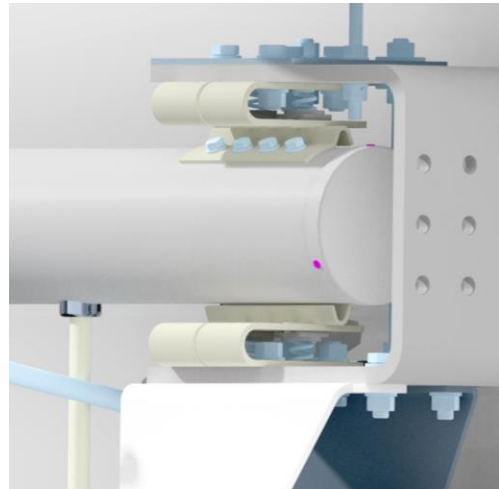

The opening and closing system of the RDA disconnecter occurs with a double kinematics system, assuring more safety at the contact, even in short-circuit. During the closing, the first movement approach the contacts and the second lock them. Only after the locking is that the torsion spring is released, making the main blade to rotate and strongly grip the contacts.

Voltage range (kV)	Atmospheric impulse withstand voltage (kV)	Nominal current (A)	Withstand current of short duration - 1s (kA)	Peak current (kA)
72,5	350	Up to 3150	50	130
145	650	Up to 4000	50	130
245	950-1050	Up to 4000	63	160
362	1175	Up to 4000	63	160



BC disconnector

Central Opening – BC:

Disconnector constituted by two rotative insulating columns which supports the movable contacts. The closing is realized in the center of the opening.

Main Characteristics



Ideal for applications in substations where the space between phases is limited.



Main blade built of aluminum plate.



Conducting electrical current in the joints through a bundle of tinned copper foils.



High operating interval before decommissioning.

Available attachments

Earthing switch

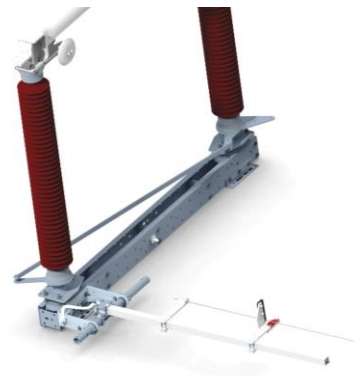

Bus transfer

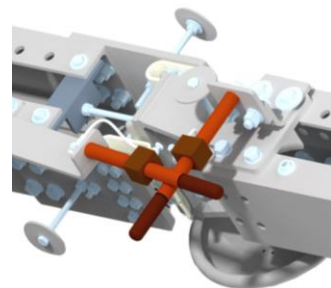

Adaptable to customers needs

The disconnector arrange can be side by side or aligned. It is also possible to adapt for higher nominal and short-circuit currents. Furthermore, the modular design allows future installations of the available attachments.

Mounting bases



Each pole from the BC disconnector is mounted over a galvanized steel base. The bases are compact and designed to support high mechanical loads. High quality bearings are used, which are maintenance and lubrication free.



The product package is optimized developed, reaffirming the Siemens Energy compromise with the preservation of the natural resources.

Contact system

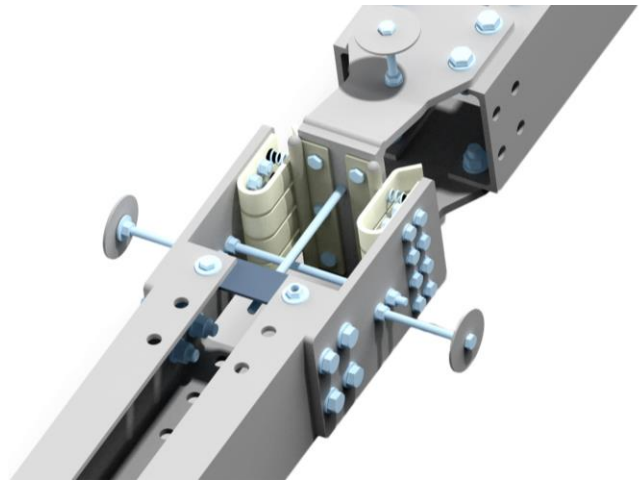

The BC disconnector main contact system is of a “Reverse Loop” type, in which there is a set of contact fingers at one end of the active part, and a vertical contact attachment at the other.

Voltage range (kV)	Atmospheric impulse withstand voltage (kV)	Nominal current (A)	Withstand current of short duration - 1s (kA)	Peak current (kA)
72,5	350	Up to 3150	40	104
145	650	Up to 3150	40	104
170	750	Up to 3150	40	104
245	950 – 1050	Up to 3150	40	104



EVR disconnector

Reverse Vertical Opening – EVR:

Disconnecter ideal for uneven busbar. It is constituted by two insulating columns, being one fixed and other rotative, that supports the main blade, and another fixed insulating column which is inverted.

Main Characteristics



Ideal for uneven busbar



The locking system assures contact even during 40kA short-circuit.



Can be directly connected to the busbar, dismissing the inverted insulating column.

Available attachments

Earthing switch

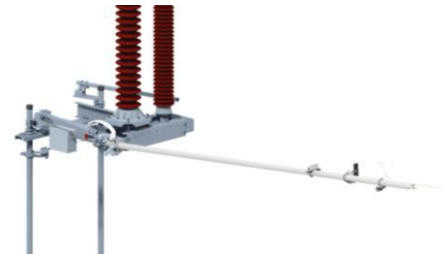

Bus transfer

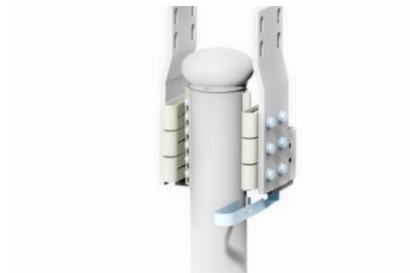

Adaptable to customers needs

The disconnector arrange can be side by side or aligned. It is also possible to adapt for higher nominal and short-circuit currents. Furthermore, the modular design allows future installations of the available attachments.

Mounting bases



Each pole from the EVR disconnecter is mounted over a galvanized steel base. The bases are compact and designed to support high mechanical loads. High quality bearings are used, which are maintenance and lubrication free.



The product package is optimized developed, reaffirming the Siemens Energy compromise with the preservation of the natural resources.

Contact system



The contact system of the EVR disconnecter consists of fingers that fit and are locked by a double kinematic system, ensuring the safety of the contact. During closing, the blade makes two movements: the first is to approach the fixed contact and the second is to rotate the blade. Thus, when reaching the fixed contact, the blade is locked and its adjustment is completed with the rotation, making the contacts become firmly locked.

Voltage range (kV)	Atmospheric impulse withstand voltage (kV)	Nominal current (A)	Withstand current of short duration - 1s (kA)	Peak current (kA)
72,5	350	Up to 3150	40	104
145	550-650	Up to 3150	40	104
245	950-1050	Up to 3150	40	104



LAV disconnecter

Semi-pantograph Opening – LAV:

Ideal disconnecter for uneven busbar. Constituted by two insulating columns, one fixed and one rotating, which sustains the main blade, and another fixed insulating column that is inverted or directly connected to busbar.

Main Characteristics



Has lower space requirement in the horizontal direction.



The clamp locking system ensures excellent contact even during short-circuits up to 40 kA.



Fixed contact can be mounted directly on the busbar.

Available attachments

Earthing switch

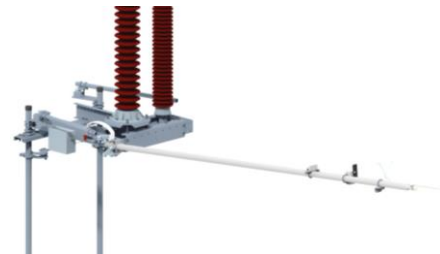

Bus transfer

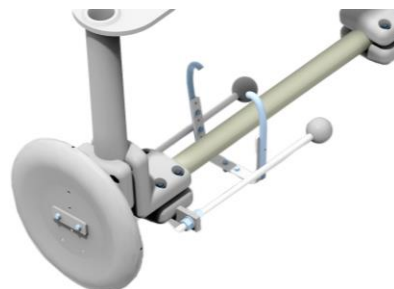

Adaptable to customers needs

The disconnecter arrange can be side by side or aligned. It is also possible to adapt for higher nominal and short-circuit currents. Furthermore, the modular design allows future installations of the available attachments.

Mounting bases



Each pole from the LAV disconnecter is mounted over a galvanized steel base. The bases are compact and designed to support high mechanical loads. High quality bearings are used, which are maintenance and lubrication free.



The product package is optimized developed, reaffirming the Siemens Energy compromise with the preservation of the natural resources.

Contact system



The contact system of the LAV disconnecter is made up of clamps that lock firmly at the end of the movement. The clamps are spring-locked in a double kinematic system, ensuring contact safety. During closing, the first movement brings the contacts together and from a certain point close to the busbar the second movement starts to close the clamps, locking them firmly at the end.

Voltage range (kV)	Atmospheric impulse withstand voltage (kV)	Nominal current (A)	Withstand current of short duration - 1s (kA)	Peak current (kA)
145	650	Up to 4000	40	104
245	950-1050	Up to 4000	50	130
362	1175	Up to 3150	50	130
550	1550	Up to 5000	50	130
800	2100	Up to 4000	50	130



LAH disconnector

Semi-Pantographic Opening – LAH:

It is constituted by three insulating columns, being two fixed (busbar connection) and one rotative (movable contact).

Main Characteristics



Individual levelling by pole, assuring stability and perfect leveling of the set.



The disconnector was designed considering all shorting, operating, and conductor efforts.



Perfect balance of the main blade, assuring a complete, smooth and stable maneuver.

Available attachments

Earthing switch

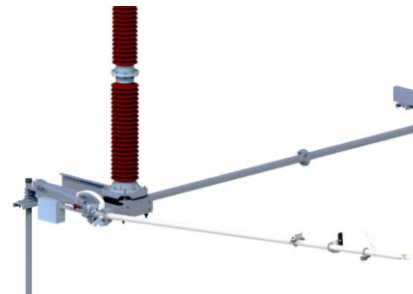

Adaptable to customers needs

The disconnector arrange can be side by side or aligned. It is also possible to adapt for higher nominal and short-circuit currents. Furthermore, the modular design allows future installations of the available attachments.

Mounting bases



Each pole from the LAH disconnector is mounted over a galvanized steel base. The bases are compact and designed to support high mechanical loads. High quality bearings are used, which are maintenance and lubrication free.



The product package is optimized developed, reaffirming the Siemens Energy compromise with the preservation of the natural resources.

Contact system

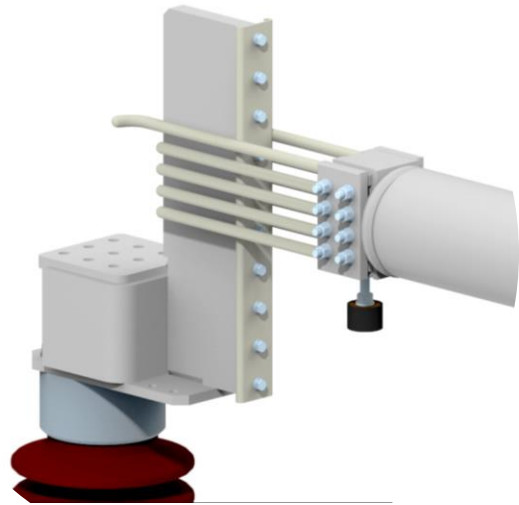

The LAH disconnector contact system is made up of fingers that are firmly attached in the end of the movement. The shape and number of fingers are specifically designed to ensure better locking with an excellent electrical connection.

Voltage range (kV)	Atmospheric impulse withstand voltage (kV)	Nominal current (A)	Withstand current of short duration - 1s (kA)	Peak current (kA)
245	950-1050	Up to 3150	40	104
362	1175	Up to 3150	50	130
550	1550	Up to 5000	50	130

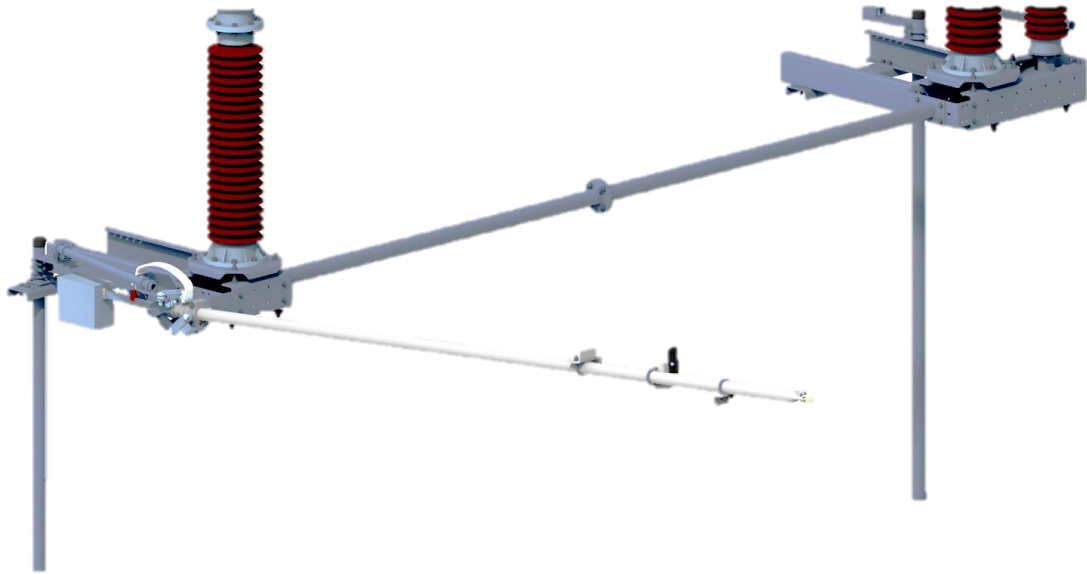

GTF disconnecter

Earthing switch – GTF:

The earthing switch is a set constituted by a command and a grounding blade, which can already be assembled or bought later.

Main characteristics



It is a modular component and fits to every product.



Has a mechanical interlock system that prevents short-circuits.



Counterweights are dimensioned at the factory.



Designed lifetime for over 30 years.

Adaptable to customers needs

The earthing switch TC/GTF are adaptable to any project needs. They can be acquired along with the disconnecter set or in a later purchase, not affecting the disconnecter operation and/or the earthing blades.

Mounting bases



Each pole from the GTF disconnecter is mounted over a galvanized steel base. The bases are compact and designed to support high mechanical loads. High quality bearings are used, which are maintenance and lubrication free.



The product package is optimized developed, reaffirming the Siemens Energy compromise with the preservation of the natural resources.

Contact system

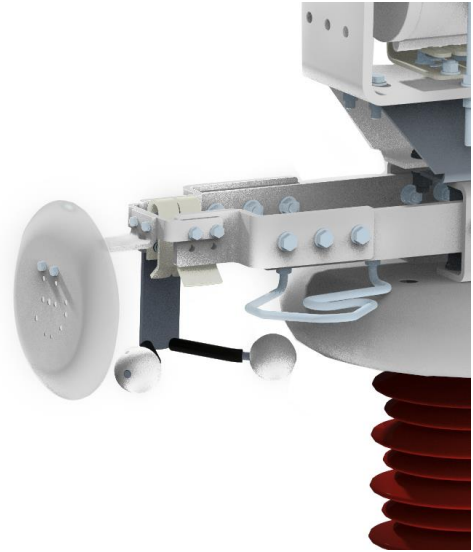

The GTF disconnecter contact system is constituted by fingers that strongly fit together and are locked by a double kinematics system, assuring the contact safety. During the closing, the first movement lead the fingers to the contact, and the second shifts the blade up, fixing it in its contact.

Voltage range (kV)	Atmospheric impulse withstand voltage (kV)	Withstand current of short duration - 1s (kA)	Peak current (kA)
145	650	63	160
245	950-1050	63	160
362-550	1175	63	160
420	1175	50	130
550	1175	50	130
880	2100	50	130

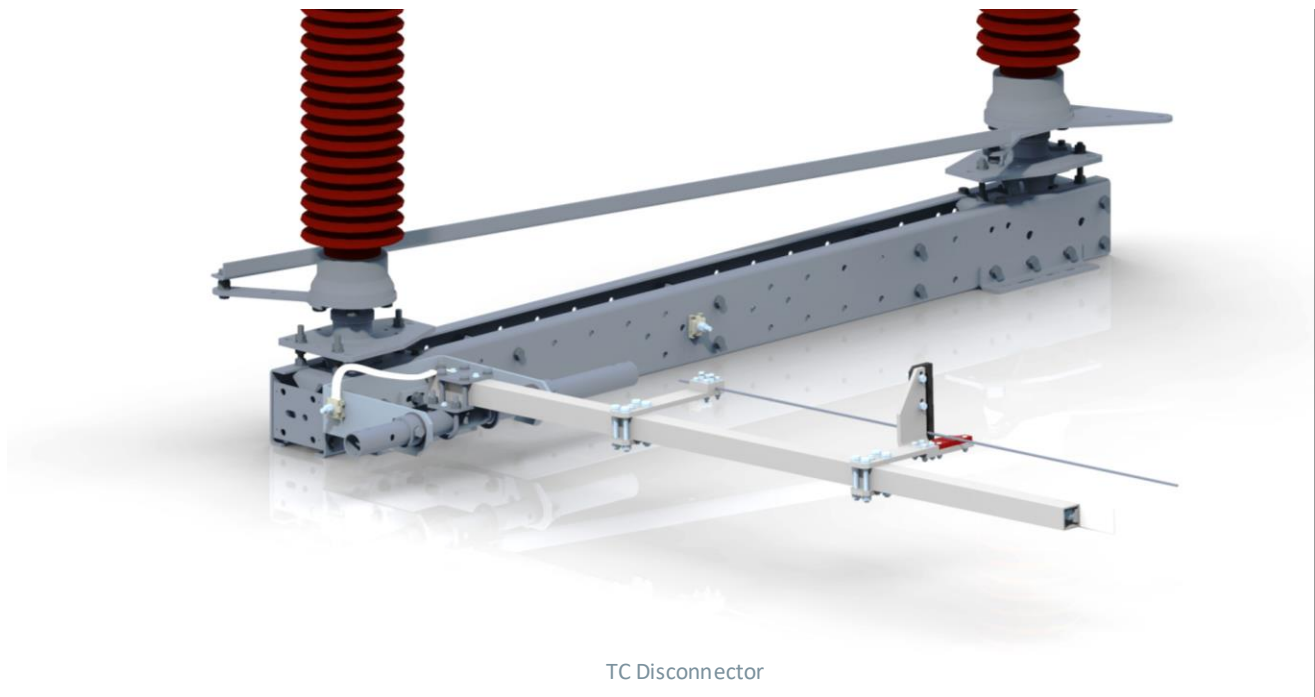

TC Disconnecter

Earthing switch – TC:

The earthing switch is a set constituted by a command and a grounding blade, which can already be assembled or bought later.

Main characteristics



It is a modular component and fits to every product.



Has a mechanical interlock system that prevents short-circuits.



Counterweights are dimensioned at the factory.



Designed lifetime for over 30 years.

Adaptable to customers needs

The earthing switch TC/GTF are adaptable to any project needs. They can be acquired along with the disconnecter set or in a later purchase, not affecting the disconnecter operation and/or the earthing blades.

Mounting bases



Each pole from the TC disconnecter is mounted over a galvanized steel base. The bases are compact and designed to support high mechanical loads. High quality bearings are used, which are maintenance and lubrication free.



The product package is optimized developed, reaffirming the Siemens Energy compromise with the preservation of the natural resources.

Contact system



The TC earthing switch contact system occurs through the simple locking system. The main blade contains a silver contact. This bar connects to the fixed contact that contains pressure springs, strengthening the electrical connection and preventing the switch from opening.

Voltage range (kV)	Atmospheric impulse withstand voltage (kV)	Withstand current of short duration - 1s (kA)	Peak current (kA)
72,5	350	31,5	82
145	550-650	31,5	82
170	750	31,5	82

Published by

Siemens Energy

Av. Engenheiro João Fernandes Gimenes Molina, nº 1745,
13213-080 Jundiaí – SP, Brasil

For more information, please visit our website:
[siemens-energy.com/website](https://www.siemens-energy.com/website)

The information contained in this document is general descriptions about the technical possibilities of the equipment. The intended performance characteristics must be determined case-by-case at the moment of contract signature. Any other demands, contact us for more information.

THIS DOCUMENT CAN BE MODIFIED WITHOUT PREVIOUS WARNING