

3AV1 Blue Circuit Breaker™

Clean air technology in our live tank
circuit breaker with Zero SF₆

[siemens-energy.com/blue-products](https://www.siemens-energy.com/blue-products)

SIEMENS
ENERGY

Vacuum technology

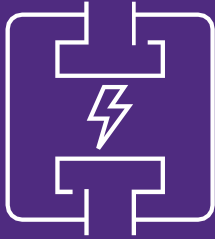

Clean air



Blue



Zero harm means Zero SF₆

As the energy industry continues to strive for Net Zero, it is essential to achieve Zero Global Warming Potential (GWP) in the transmission of power as well as in its generation. That means the elimination of climate-hostile fluorinated gases (F-gases) from electrical switchgear – especially SF₆.

Recent EU legislation has restricted the use of these gases, with a full ban likely in the near future. Clean air insulation with vacuum switching technology is the way forward, since this involves Zero greenhouse gases of any kind and has Zero harmful impact on the environment.

The clean air technology used in the Siemens Energy Blue portfolio is well proven and already in operation worldwide – with the 3AV1 Blue live tank being a prime example of how using Zero F-gases means Zero compromise on performance.

Extensive experience

The technology is long established. We have 40 years of experience in producing medium-voltage vacuum interrupters suitable for power networks up to 52 kV, and this capability has been extended to the high-voltage 145 kV level.

Prototypes of these breakers began to operate on a number of sites in 2010, and the 3AV1 model has been in production since 2017 with more than 150 units delivered worldwide.

Like all our circuit breakers, the 3AV1 LT is designed using a tried and tested modular platform concept. The operating mechanism, control system, base frame, kinematic chain and insulator designs are based on decades of manufacturing and operating experience.

High-voltage, high-performing vacuum technology

The 3AV1 delivers the high levels of performance and reliability our customers have come to expect from our circuit breakers:

- Reliable making and breaking capabilities
- 30 full short-circuit current interruptions
- 10,000 rated current interruptions
- Optional 2-cycle current interruption
- Full performance down to -60° C ambient temperature
- Zero-maintenance interrupter unit (full lifetime)
- Tested in accordance with IEC 62271-100, -110, -310

With Zero F-gases and Zero compromise on performance, the 3AV1 Blue Live Tank circuit breaker is helping to make a greener grid achievable.

Zero environmental impact

- Zero SF₆ and other F-gases
- Zero greenhouse gas emissions
- Zero GWP

Zero impact on health & safety

- Zero toxic insulation gases
- Zero toxic decomposition products
- Zero special safety measures needed during maintenance
- Zero disposal of gases required at end of life

Zero regulation

- Zero regulations on handling of gas
- Zero reporting and accounting of gases required
- Zero F-gas training needed
- Zero issues with current and potential legislation against PFAS F-gases

Zero compromise on performance and reliability

- High number of short-circuit and rated current interruptions
- Two-cycle current interruption
- 10+ years of experience in high-voltage vacuum switching applications up to 145 kV
- Perfect for lowest temperature applications
- Near-Zero maintenance required

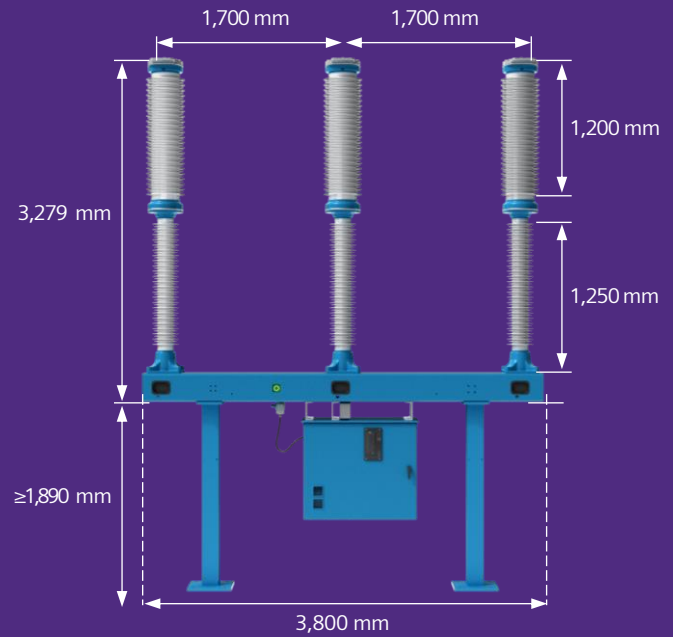

Dimensions of the 3AV1 Blue Live Tank

Technical details

Rated voltage	up to 145 kV*
No. of operations at rated short-circuit breaking current (40 kA)	30
No. of interrupter units per pole	1
No. of operations at rated normal current (3,150 A)	10,000
Rated break time	3 cycles and 2 cycles
Rated normal current, up to	3,150 A
Rated short-time withstand current, up to	40 kA
Rated short-circuit breaking current, up to	40 kV
Rated frequency	50/60 Hz
Rated power-frequency withstand voltage	275 kV
Rated lightning impulse withstand voltage	650 kV
Rated duration of short-circuit	3 s
Rated peak withstand current (2.7 p.u.)	108 kA
First-pole-to-clear factor	1.5 / 1.3 p.u.
Capacitive voltage factor	1.4 p.u.
Temperature range	-60 up to +55 °C
Maintenance schedule	12 years: visual inspection and checks; up to 10,000 operations at 3,150 A
Insulating medium	clean air
Mass of fluorinated greenhouse gases / mass of CO ₂ equivalent	0 kg / 0 t

All values in accordance with IEC; other values on request

*on request as 145 kV 60 Hz circuit switcher in acc. with IEEE/ANSI



SF₆ vs. Clean air

GWP of the entire product life cycle:

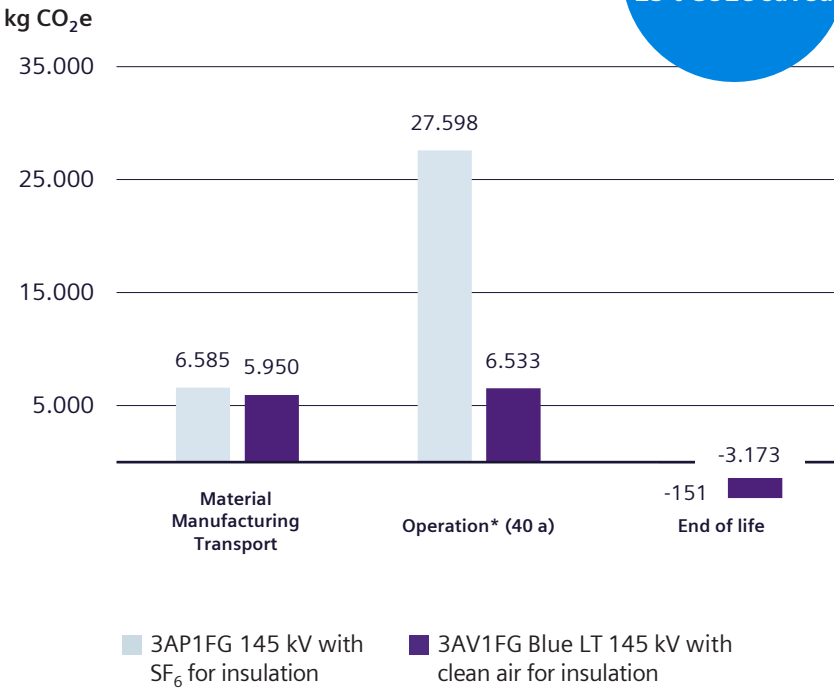

*GWP of insulation gas = 0; GWP of power losses depends on generation mix: for renewable energy mix e.g. hydro, wind is GWP = 0

Global Warming Potential (GWP)

Global warming is the rising of the global temperature due to emissions of greenhouse gases. The 8VN1 reduces the GWP significantly by substituting SF₆.

SF₆

- High environmental impact
- Costs for special maintenance tools
- Costs for special trainings
- Costs for reporting and taxes
- Costs for gas recycling

Clean air

- + No environmental impact
- + Non-toxic, non-hazardous
- + Maintenance-free
- + Training-free
- + Reporting-free
- + Gas recycling-free

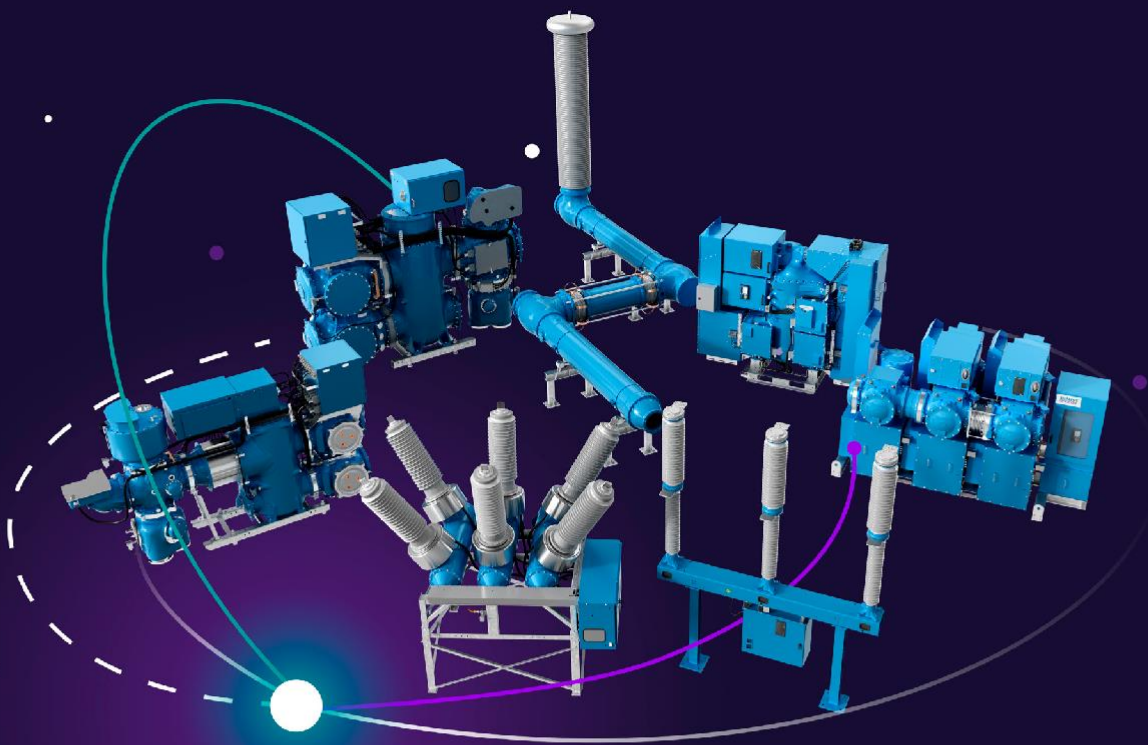

Siemens Energy Blue portfolio covers many more F-gas free product lines and ratings.
Learn more at [siemens-energy.com/blue-products](https://www.siemens-energy.com/blue-products)

Published by

Siemens Energy Global GmbH & Co. KG
Grid Technologies
Siemenspromenade 9
91058 Erlangen
Germany

For more information, please visit our website:
[siemens-energy.com/circuit-breakers](https://www.siemens-energy.com/circuit-breakers)

or contact us via Email:
support@siemens-energy.com

© Siemens Energy, 2025

Siemens Energy is a trademark licensed by Siemens AG.

For the U.S. published by

Siemens Energy, Inc.
Grid Technologies
8841 Wadford Drive
Raleigh, NC
USA

Subject to changes and errors. The information given in this document only contains general descriptions and/or performance features which may not always specifically reflect those described, or which may undergo modification in the course of further development of the products. The requested performance features are binding only when they are expressly agreed upon in the concluded contract. All product designations may be trademarks or product names of Siemens Energy Global GmbH & Co. KG or other companies whose use by third parties for their own purposes could violate the rights of the owners.