

E-STATCOM for data centers

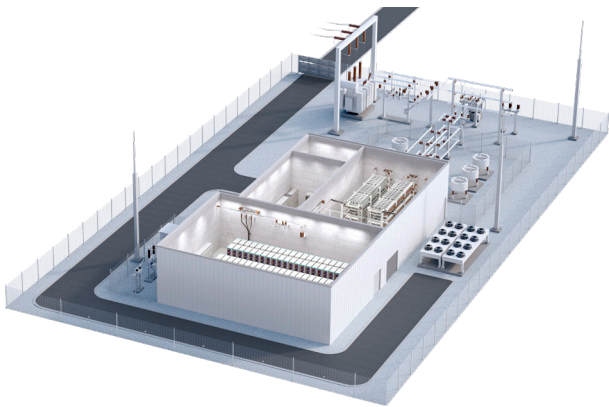
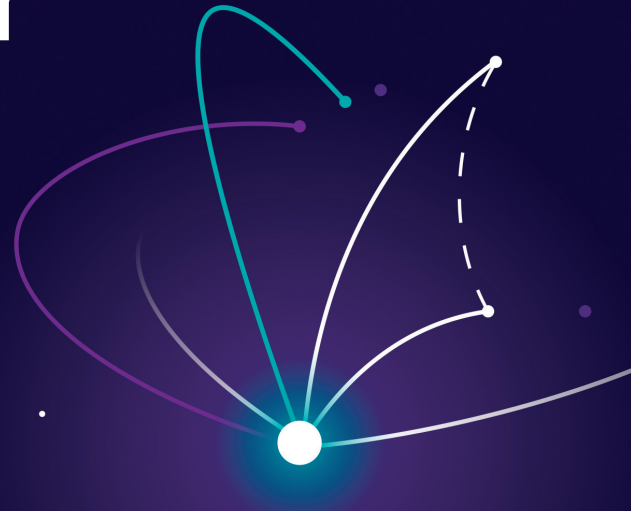

Introduction

Data centers represent significant electrical loads, often reaching gigawatt levels. In addition AI data centers produce load fluctuations. The fluctuations are in the subsynchronous frequency range down to very low frequencies matching with interarea power oscillations or sub synchronous oscillations, a widely known phenomena in the operation of electrical systems. This can cause instabilities in the transmission grid or in islanded grids. The E-STATCOM for data center applications is a STATCOM additionally equipped with super-capacitors and a dedicated control system, which actively mitigates the load fluctu-

ations directly at the load. This reduces the load fluctuations by smoothing the active power load pattern at the point of connection. It maintains the power quality of the electrical system within the permissible range. The E-STATCOM for data center applications is based on proven PLUS technology by Siemens Energy, relied on by hundreds of utilities.

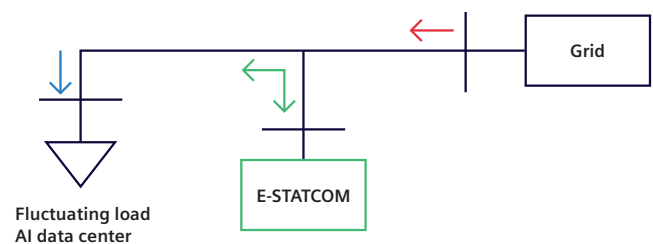

Working principle

The E-STATCOM is connected at or behind the point of coupling of the AI data center in parallel to the load and compensates for the active power load swings. At the same time, the E-STATCOM can provide or absorb reactive power from the grid or the load. This stabilizes the electrical system's voltage.

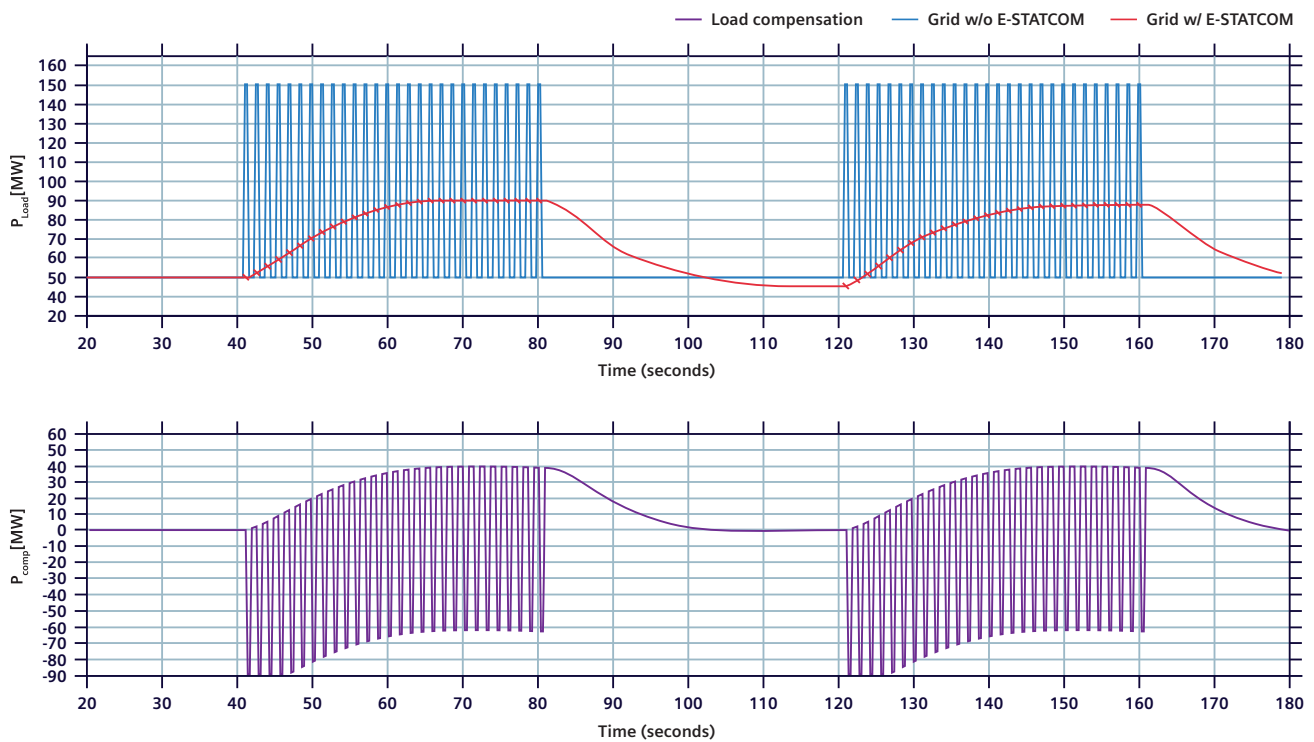

Data centers for AI-computing show high fluctuating active power cycles. The E-STATCOM compensates the alternating load cycles by injecting out of, or absorbing active power into, its short-term storage unit.

The above diagram shows the resulting red active power demand from the grid, if E-STATCOM is in operation. The blue line shows the active power demand without E-STATCOM, the purple line shows the load compensation.

Features and functions

The E-STATCOM for data center applications provides typical STATCOM features on top of the active power damping. The main features are

- Active power compensation
- Reactive power compensation
- Voltage control
- Flicker compensation
- Peak load shaving
- Enhancing the load fault ride-through capability

Ratings

One unit has the following rating:

Parameter	Value
Installed power S_{nom}	115 MVA
Reactive power Q_{nom}	+/- 75 MVar
Active power cycle	+/- 75 MW
Connection voltage	Any voltage from 34.5 kV to 750 kV

The modular design of the system allows for easy expandability, enabling multiple units to be installed in parallel and coordinated effectively.

Scope

The Siemens Energy solution for an E-STATCOM is referred to as SVC PLUS FS[®], which is represented schematically in the single-line diagram below. The E-STATCOM for data centers is equipped with a Modular Multilevel Converter (MMC), connected in B6-topology, which provides the reactive and active power control. The DC terminals of the MMC are connected to an energy storage unit, consisting of bulk numbers of supercapacitors. The modular

approach in design provides the possibility of adding parallel branches to achieve higher power ratings.

Supercapacitors were identified as the optimal choice of storage element due to their high power density, low internal resistance and long service life independent from the number of load cycles. During active power load compensation, supercapacitors are capable of providing or absorbing high levels of active power in the shortest response time aligning perfectly with the requirements of highly dynamic variable load compensation.

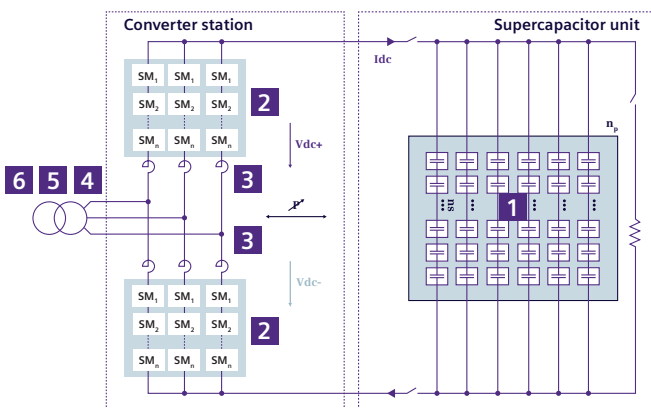

Main components:

- 1 Super capacitor storage
- 2 Multilevel converter
- 3 Phase shifting reactors
- 4 MV switchyard
- 5 Power transformer
- 6 HV switchyard

Further scope:

Control and protection system, cooling system, auxiliary supply, electrical and mechanical building supply, civil installation.

Services:

Engineering, Procurement, Delivery, Installation, Commissioning

Scope split between customer and Siemens Energy can be discussed. From full turnkey solution to equipment supply only. On request, a containerized solution is possible.

Layout

The E-STATCOM for data center applications features standardized components in a standard layout that can be adjusted to site conditions. A 75 MW unit has a footprint of approx. 300x100 ft (90 x 30 m).

Communications

The following image shows the communication topology.

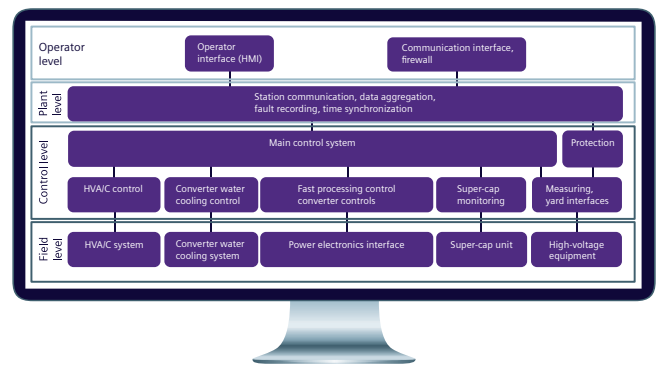

The control system topology is a fully integrated and automated control system. The system can be operated completely remotely via the Scada interface (e.g. DNP 3.0 or IEC61850). A service interface for remote access is integrated. The system is NERC CIP cyber security compliant.

Availability

The E-STATCOM for data center applications complies with availability standards per CIGRE TB 717 for bulk electrical systems. Redundancy is built in within the system, so optimum availability can be guaranteed.

Testing

All systems are type-tested based on our type design for the E-STATCOM for utility applications. Factory testing is done during project execution.

All components are tested on insulation, operational currents and short circuits. The control

system is comprehensively tested through EMT-simulations with embedded original control codes and with a real time simulator (RTDS) as hardware in the loop test. Factory routine tests are performed for all systems to guarantee premium quality and customer satisfaction.

Manufacturing

The modular multilevel converter is based on the Siemens Energy PLUS technology, which is manufactured in the Siemens Energy converter factory in Nuremberg, Germany, and is used worldwide in HVDC and STATCOM applications. The supercapacitor energy storage is manufactured and tested in Germany. The control system is manufactured and tested by Siemens Energy.

Civil and installation

The system consists of outdoor and indoor equipment. The indoor equipment will be installed in a predesigned building, which can be constructed by a construction company for substations or other industrial facilities.

The installation of the system is standardized and can be performed by companies experienced in substation works. Siemens Energy uses a wide range of subcontracted suppliers. Installation supervisors will be from Siemens Energy. The commissioning is performed by experienced Siemens Energy experts.

References

The E-STATCOM for AI data center applications is based on the E-STATCOM system for utility applications. In Germany one installation will go into service in 2025. Siemens Energy was the first who introduced the modular multilevel converter technology and has an installed base of more than 150 systems of this kind with more than 15 years of operational experience.

Published by

Siemens Energy Global GmbH & Co. KG
Grid Technologies
Siemenspromenade 9
91058 Erlangen
Germany

For the U.S. published by

Siemens Energy, Inc.
Grid Technologies
4912 Green Road
Raleigh, NC 27616
USA

For more information, please visit our website:

[siemens-energy.com/transmission](https://www.siemens-energy.com/transmission)

or contact us: support.energy@siemens-energy.com

© Siemens Energy, 2025

Subject to changes and errors. The information given in this document only contains general descriptions and/or performance features which may not always specifically reflect those described, or which may undergo modification in the course of further development of the products. The requested performance features are binding only when they are expressly agreed upon in the concluded contract. All product designations may be trademarks or product names of Siemens Energy Global GmbH & Co. KG or other companies whose use by third parties for their own purposes could violate the rights of the owners.

Siemens Energy is a trademark licensed by Siemens AG.