

Spare Parts Glossary

Spare Parts for Siemens Energy
Gimpel Valves

For best viewing experience, please open this interactive PDF
in the Acrobat PDF Viewer 10.0 or higher.

Visit our website: [siemens-energy.com/steamturbines](https://www.siemens-energy.com/steamturbines)

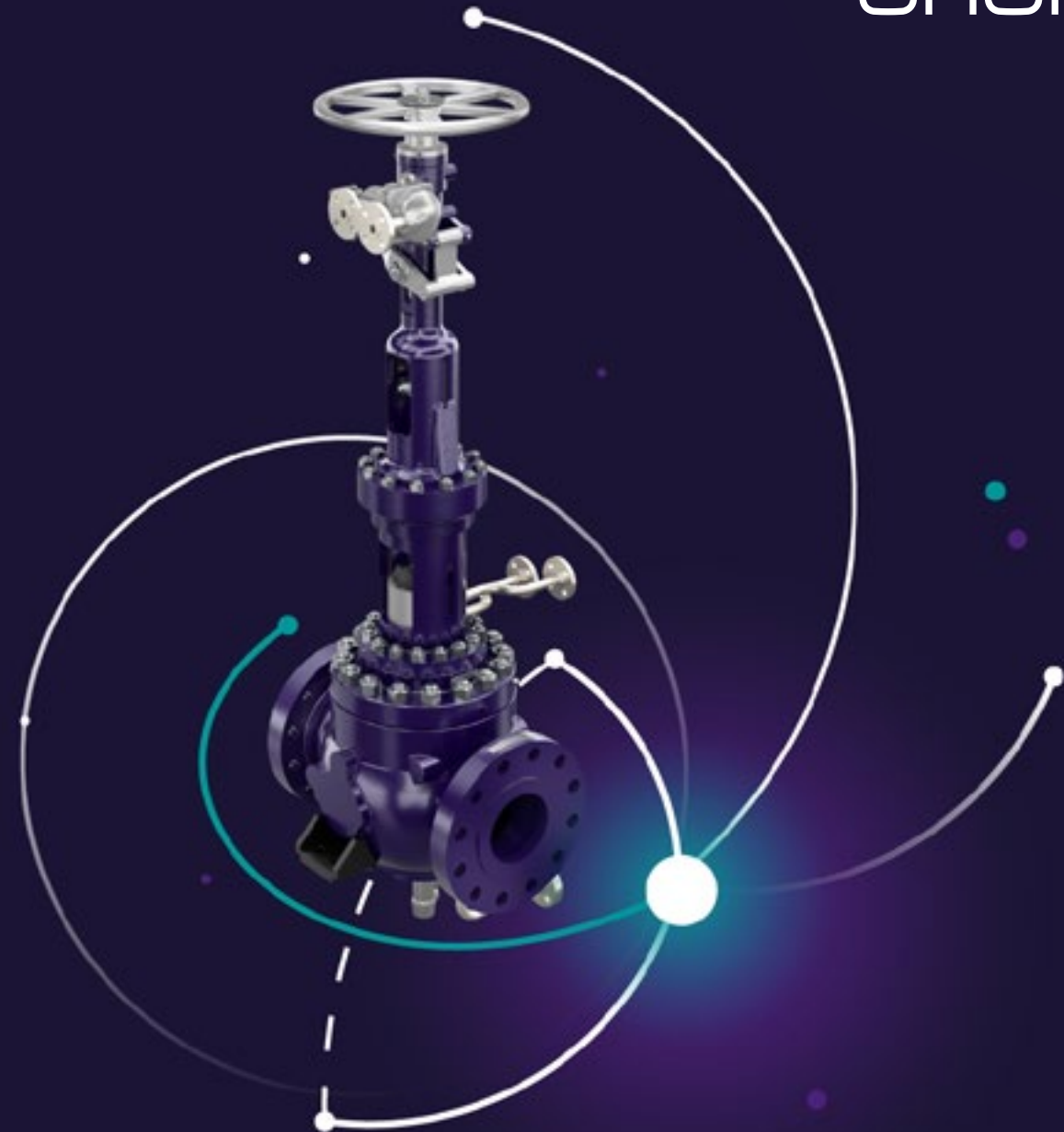

1. Steam Path Valve body and Components I

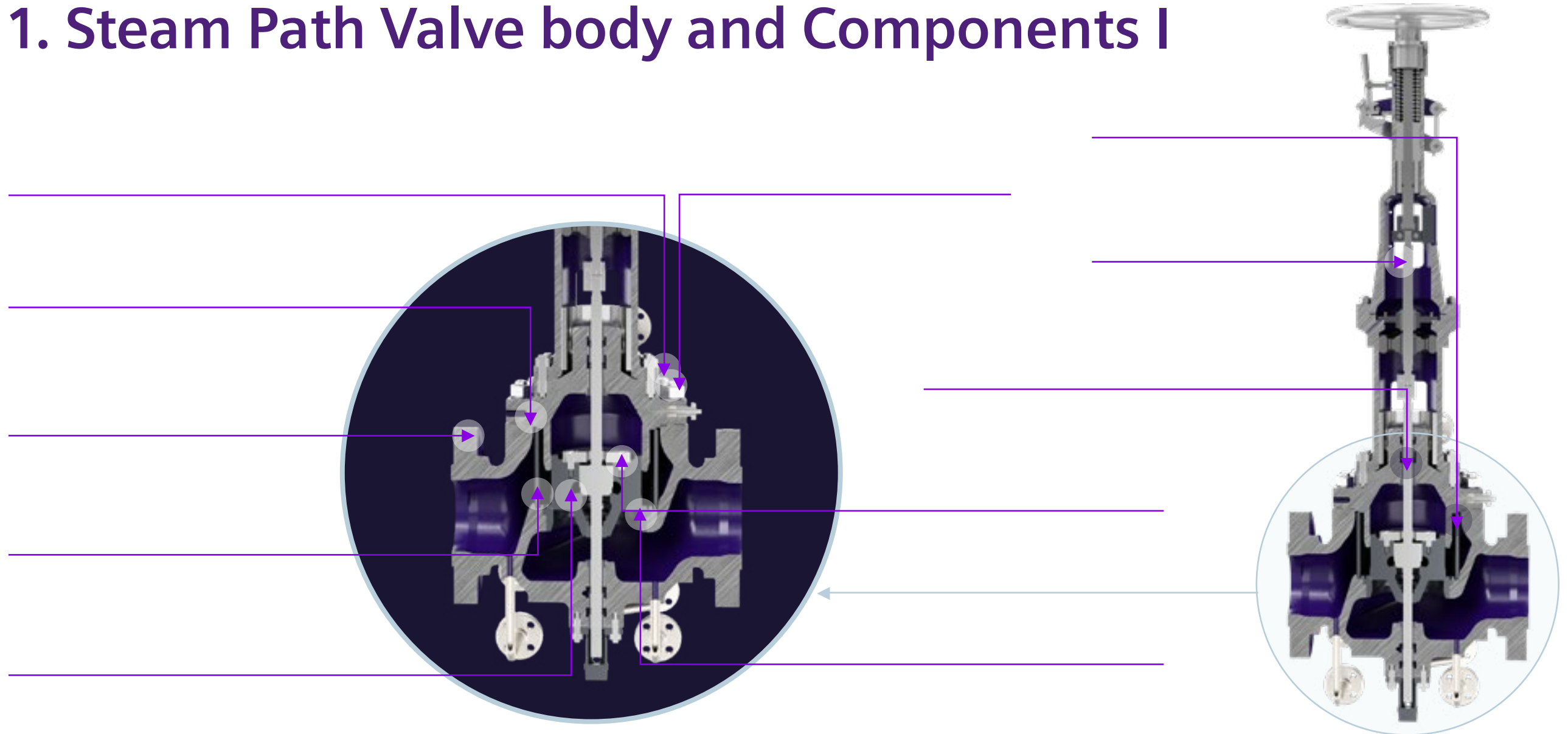

1. Steam Path Valve body and Components II

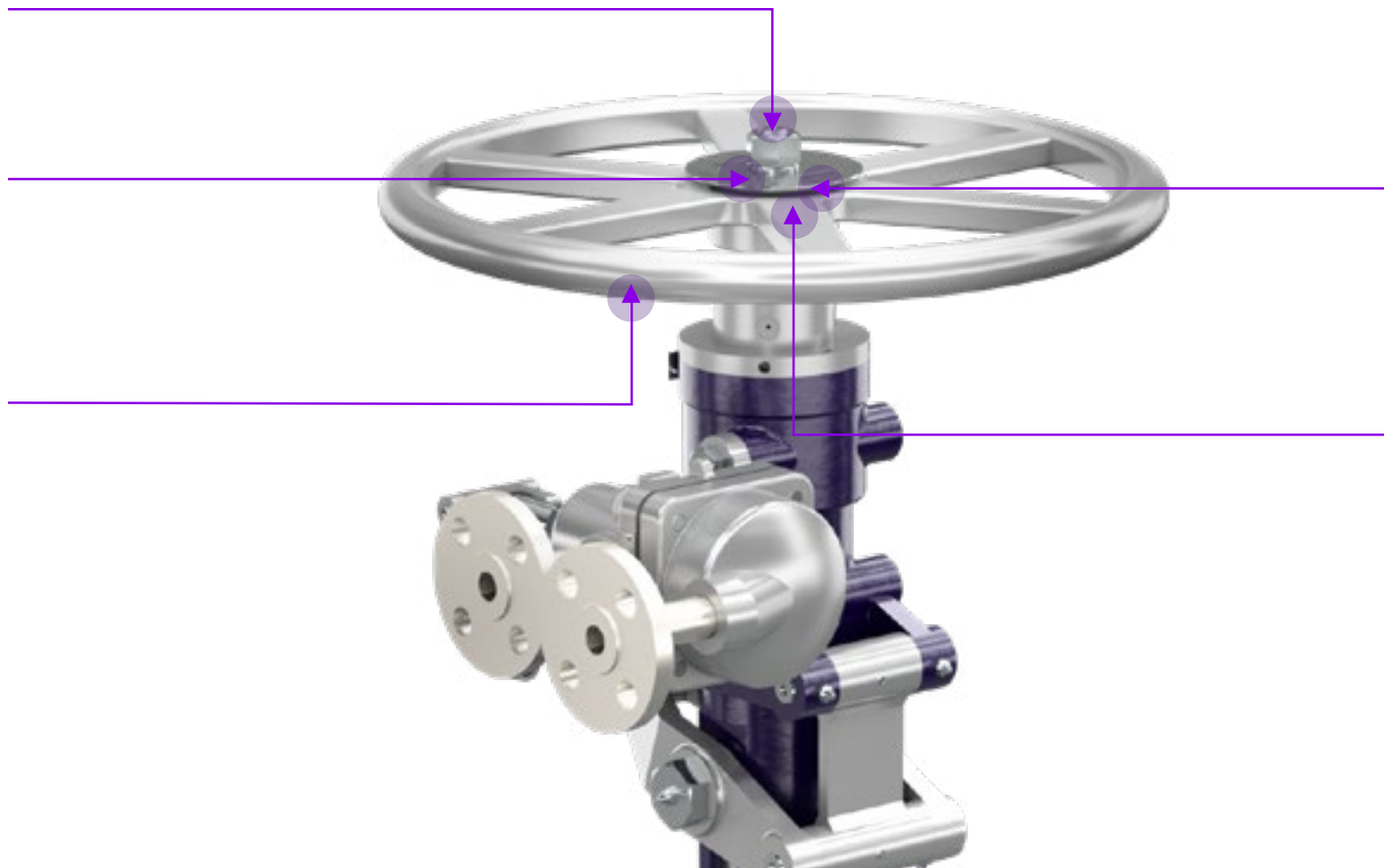

2. Yoke section I

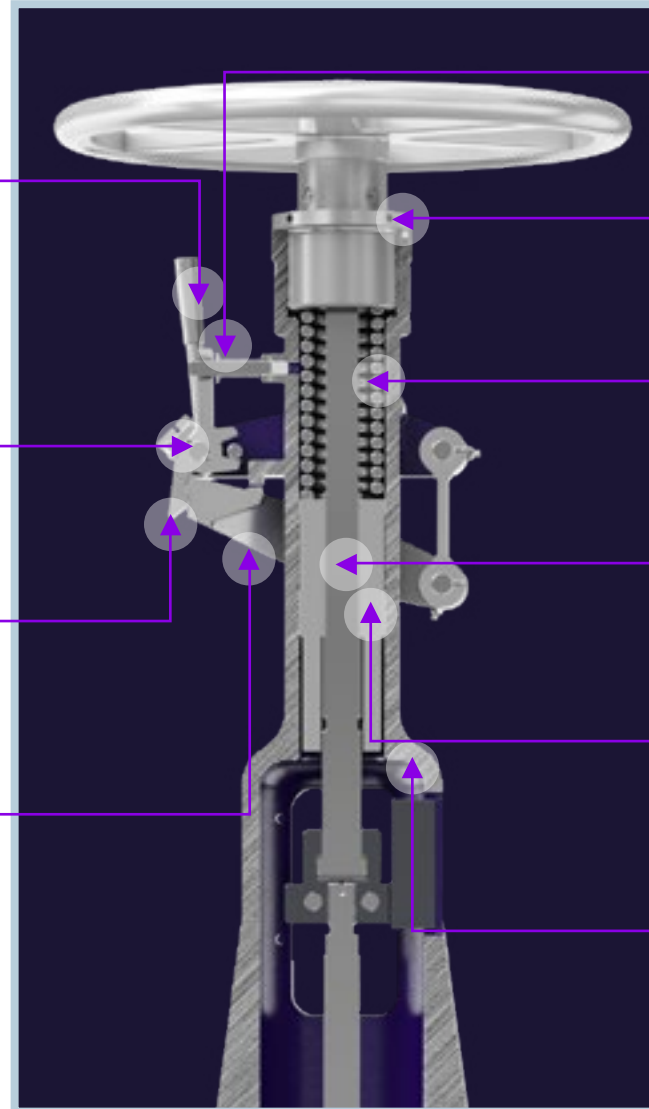
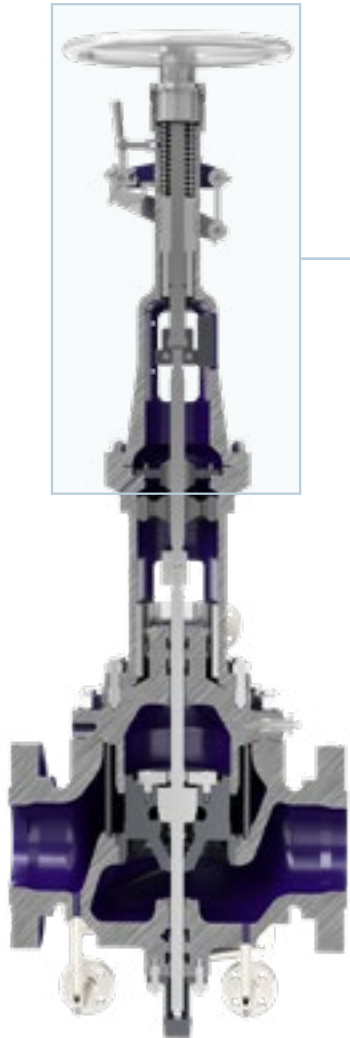

2. Yoke section II

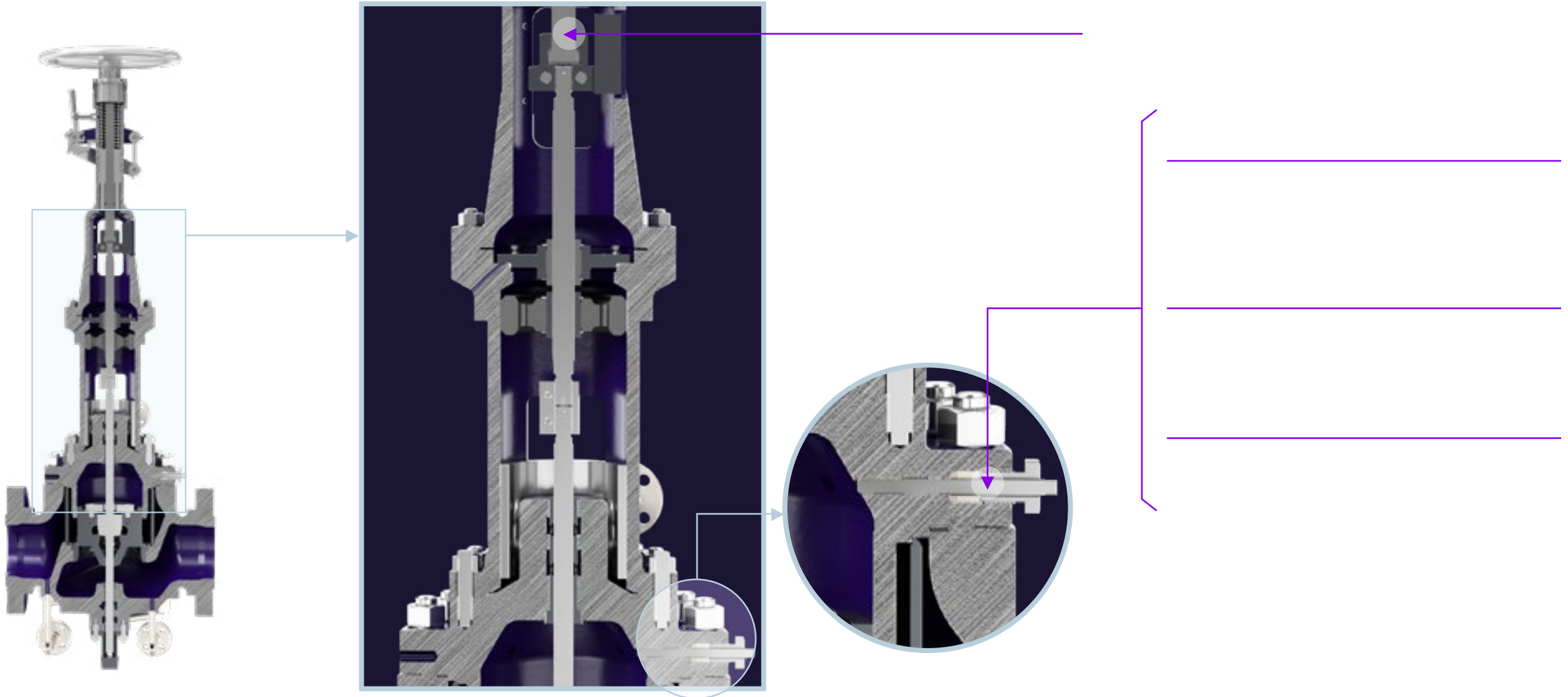

3. Oil Section

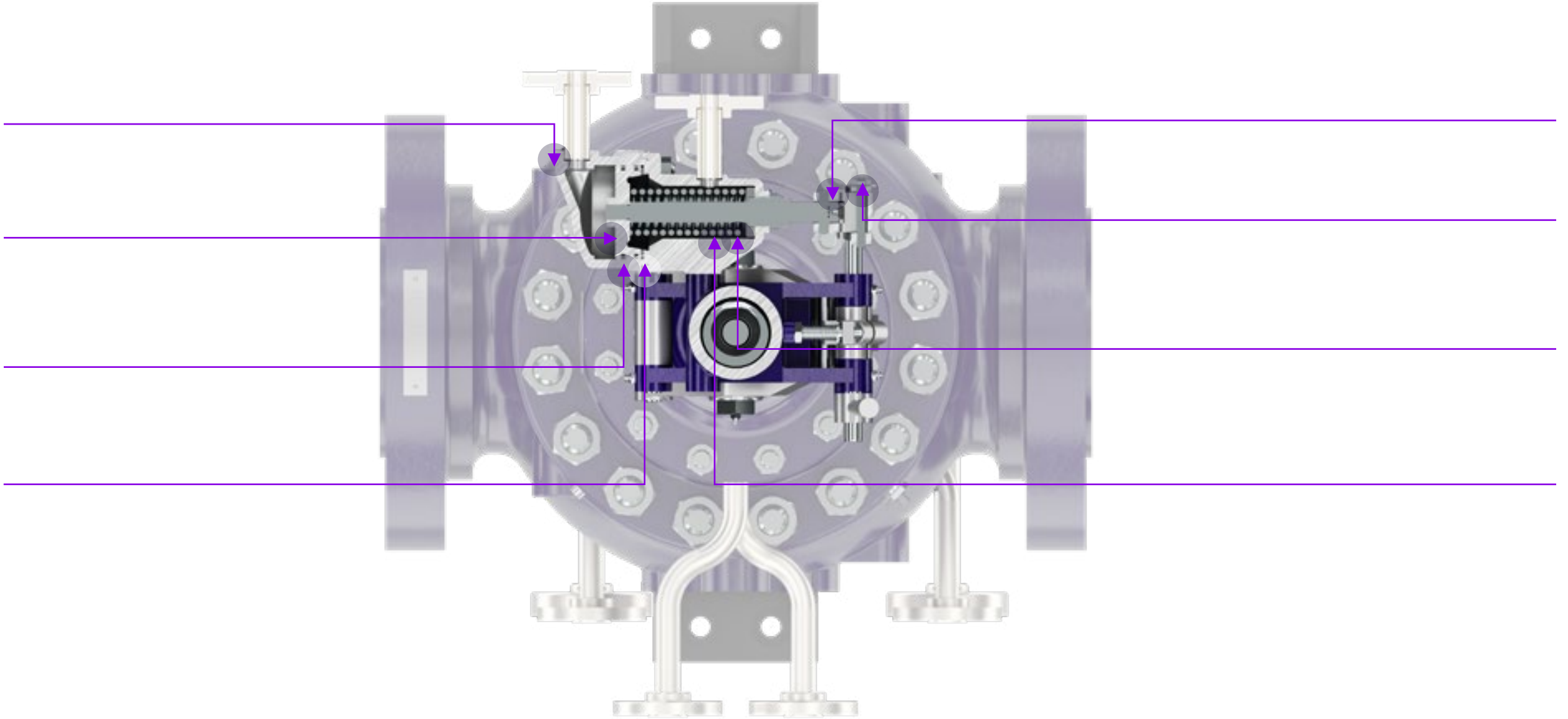

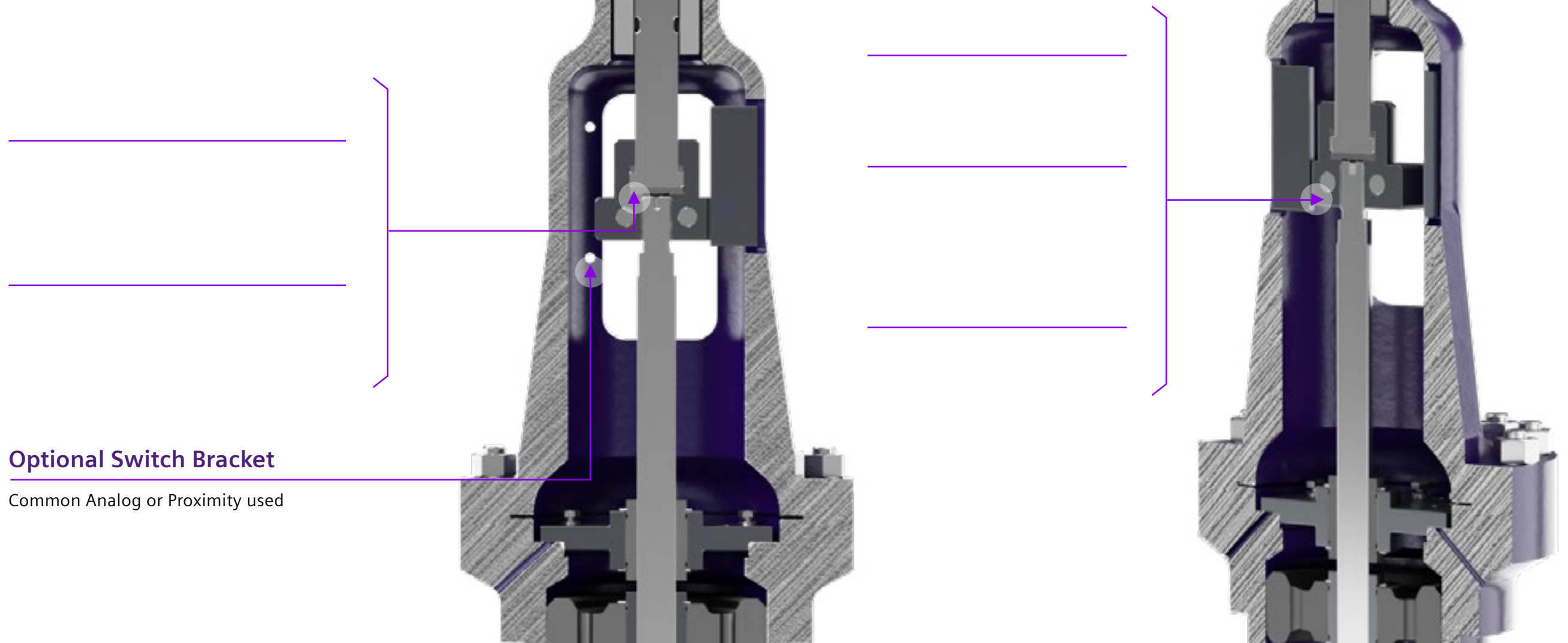

4. Coupling section



Optional Switch Bracket

Common Analog or Proximity used

 [siemens-energy.com](https://www.siemens-energy.com)

 x.com/siemens_energy

 [linkedin.com/siemens-energy](https://www.linkedin.com/siemens-energy)



Published by and copyright © 2025:

Siemens Energy Global GmbH & Co. KG
Freyeslebenstrasse 1
91058, Erlangen, Germany

Siemens Energy Inc.
15375 Memorial Drive, Suite 700
Houston TX 77079, USA

For more information, please contact our
Siemens Energy Customer Support Center
Phone: +49 (0)911 6505 6505 / +49 180 5 24 7000
(charges may apply depending on your provider)

Web: [siemens-energy.com](https://www.siemens-energy.com)

E-mail: rslparts.pgdr.energy@siemens-energy.com

Subject to changes and errors. The information given in this document only contains general descriptions and/or performance features which may not always specifically reflect those described, or which may undergo modification in the course of further development of the products. The requested performance features are binding only when they are expressly agreed upon in the concluded contract.

Siemens Energy is a trademark licensed by Siemens AG.