

# Gas turbines at combined-cycle power plants

## Configurations and technical data



Combined cycle plants are highly efficient and maximize power output by utilizing both gas and steam turbines to convert excess heat into additional electricity.

We offer a wide range of gas turbines suitable for combined cycle operation, catering to both 50Hz and 60Hz markets with options for single- and multishaft designs.

### Overview/plant power output for 1x1 and 2x1 configurations

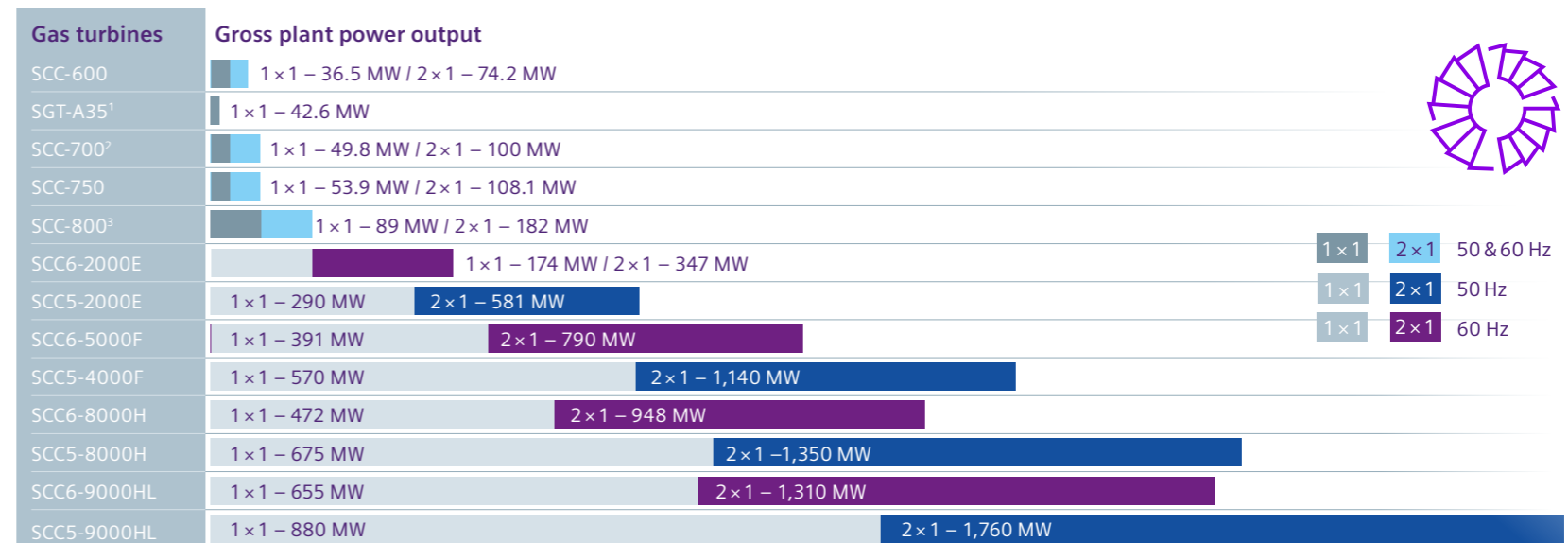

# SGT-600 Industrial gas turbine

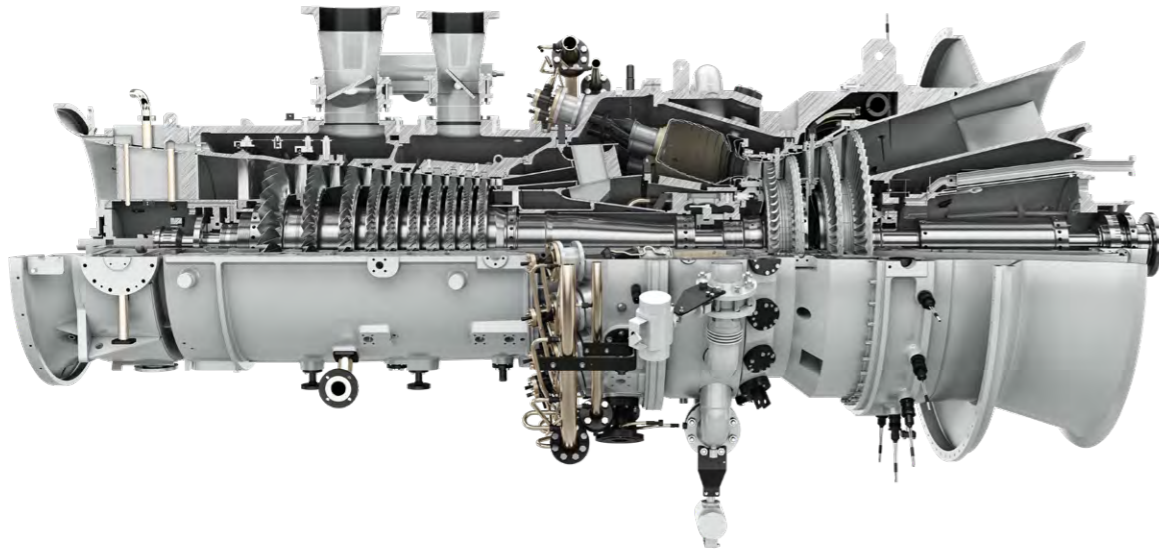

## Performance data for combined cycle power generation

Combined cycle power plant	SCC-600 1 × 1	SCC-600 2 × 1
Gross power output	36.5 MW(e)	74.2 MW(e)
Gross plant efficiency	50.7%	51.6%
Gross heat rate	7,105 kJ/kWh (6,734 Btu/kWh)	6,981 kJ/kWh (6,616 Btu/kWh)
Number of gas turbines	1	2

High reliability and availability in combination with good fuel flexibility and third-generation DLE makes the SGT-600 a perfect choice for several onshore applications: Industrial power generation, oil and gas power generation, and mechanical drive applications. Within the IPG applications, the turbine performs well in combined heat and power plants, and combined cycle plants.

Note: All combined cycle performance is based on 2 pressure, no reheat.

# SGT-35 Aeroderivative gas turbine

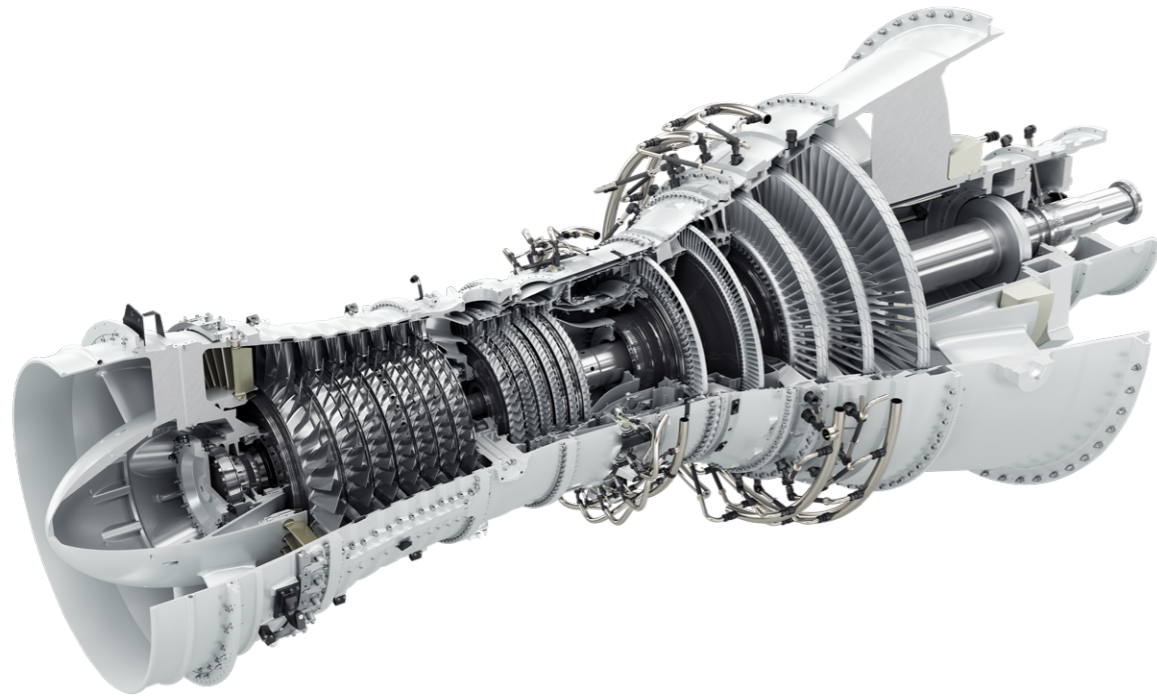

Performance data for combined cycle power generation

	SGT-A35 (GT62) DLE	SGT-A35 (GT61 34MW) DLE
Gross power output	39.8 MW(e)	42.6 MW(e)
Gross plant efficiency	51.4%	52.8%
Gross heat rate	7,005 kJ/kWh (6,639 Btu/kWh)	6,820 kJ/kWh (6,464 Btu/kWh)
Pressure/ Reheat	Dual/ No	Dual/ No

With class-leading reliability and availability, the SGT-A35 is a proven, dependable choice in power generation and mechanical drive applications. It is qualified to meet the stringent standards of the oil and gas industry in both onshore and offshore service.

All performance values are based on standard design, ISO ambient conditions and high-methane natural gas fuel. No intake or exhaust loss. All combined cycle performance is based on 2 pressure, no reheat.

# SGT-700 Industrial gas turbine

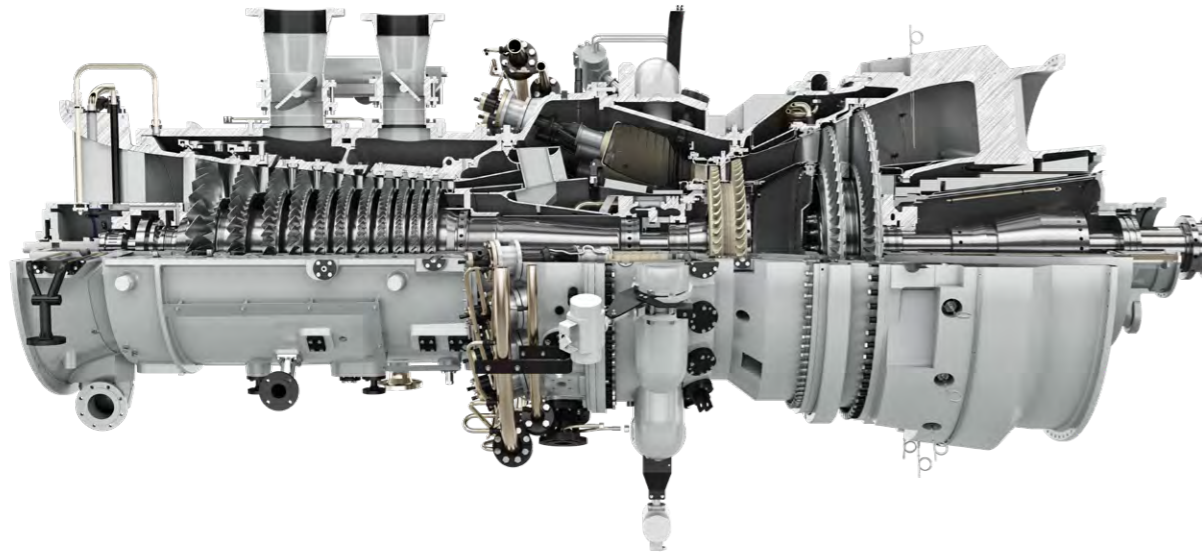

Thanks to its wide fuel range capability and design features, the SGT-700 is a perfect choice for several applications: industrial power generation, oil and gas power generation, and mechanical drive applications. It performs well in combined cycle plants, and combined heat and power plants.

## Performance data for 1 × 1 combined cycle power plant

	35 MW rating	33 MW rating
Gross power output	49.8 MW	46.7 MW
Gross plant efficiency	54.5%	54.2%
Gross heat rate	6,609 kJ/kWh (6,264 Btu/kWh)	6,648 kJ/kWh (6,301 Btu/kWh)
Number of gas turbines	1	1

## Performance data for 2 × 1 combined cycle power plant

	35 MW rating	33 MW rating
Gross power output	100 MW	92.6 MW
Gross plant efficiency	54.7%	53.7%
Gross heat rate	6,576 kJ/kWh (6,233 Btu/kWh))	6,703 kJ/kWh (6,353 Btu/kWh)
Number of gas turbines	2	2

Note: All combined cycle performance is based on 2 pressure, no reheat.

# SGT-750 Industrial gas turbine

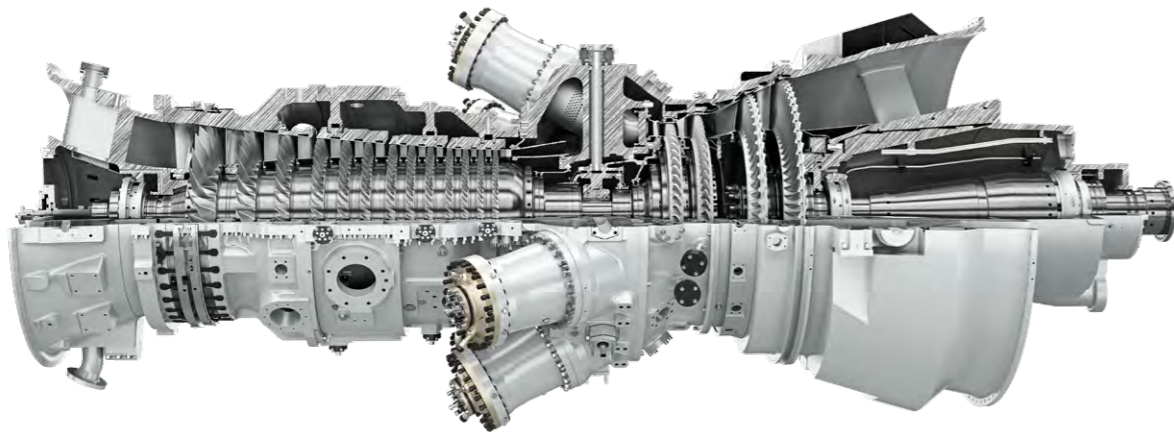

Performance data for combined cycle power plant

	SCC-750 1 × 1	SCC-750 2 × 1
Gross power output	53.9 MW(e)	108.1 MW(e)
Gross plant efficiency	54.1%	54.3%
Gross heat rate	6,656 kJ/kWh (6,309 Btu/kWh)	6,633 kJ/kWh (6,287 Btu/kWh)
Number of gas turbines	1	2

With maximized uptime, top-class performance, and a low environmental footprint offering the customer high lifetime profitability, the SGT-750 industrial gas turbine is a perfect choice for the oil and gas industry as well as industrial power generation. The modular and flexible engine enables onshore or offshore applications, mechanical drive or heat and power. It combines a robust, reliable design with high efficiency and low emissions.

All combined cycle performance is based on 2 pressure, no reheat.

# SGT-800 Industrial gas turbine

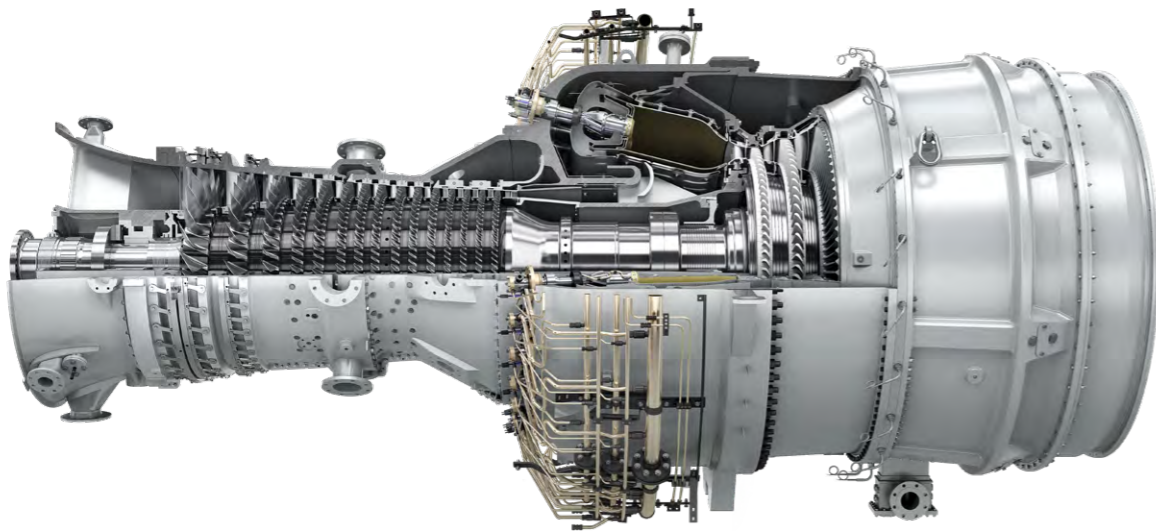

The market leading SGT-800 industrial gas turbine offers broad flexibility. The SGT-800 combines a simple, robust design, for high reliability and easy maintenance, with high efficiency and low emissions. Sustainable and future proof. Targeting 100% hydrogen capability by 2025. Continuously improving other green fuel capabilities.

Performance data for 1 × 1 combined cycle power plant

	35 MW rating	33 MW rating	56 MW rating	50 MW rating	45 MW rating
Gross power output	89 MW(e)	81.5 MW(e)	80.0 MW(e)	71.9 MW(e)	66.5 MW(e)
Gross plant efficiency	59.6%	58.5%	57.9%	57.7%	57.2%
Gross heat rate	6,040 kJ/kWh (5,725 Btu/kWh)	6,154 kJ/kWh (5,833 Btu/kWh)	6,218 kJ/kWh (5,893 Btu/kWh)	6,239 kJ/kWh (5,914 Btu/kWh)	6,294 kJ/kWh (5,965 Btu/kWh)
Number of gas turbines	1	1	1	1	1

Performance data for 2 × 1 combined cycle power plant

	62 MW rating	57 MW rating	56 MW rating	50 MW rating	45 MW rating
Gross power output	182 MW(e)	164.8 MW(e)	162.1 MW(e)	145.3 MW(e)	134.5 MW(e)
Gross plant efficiency	60.6%	59.1%	58.6%	58.3%	57.8%
Gross heat rate	5,941 kJ/kWh (5,631 Btu/kWh)	6,091 kJ/kWh (5,774 Btu/kWh)	6,143 kJ/kWh (5,823 Btu/kWh)	6,175 kJ/kWh (5,853 Btu/kWh)	6,228 kJ/kWh (5,903 Btu/kWh)
Number of gas turbines	2	2	2	2	2

The combined cycle plant SCC-800 is available based on one or multiple SGT-800 gas turbines. Combined cycle performance is based on three pressure non-reheat (3PNRH) bottoming cycle.

# SGT6-2000E Industrial gas turbine

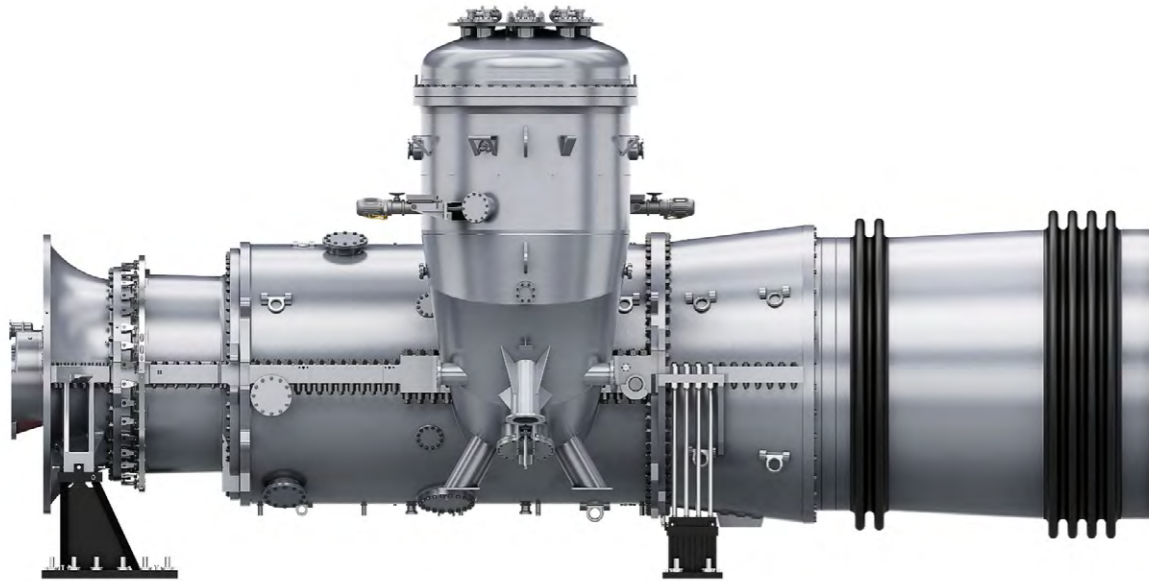

Performance data for combined cycle power plant

	SCC6-2000E 1 × 1	SCC6-2000E 2 × 1
Gross power output	174 MW	347 MW
Gross plant efficiency	52.2%	52.2%
Gross heat rate	6,894 kJ/kWh (6,533 Btu/kWh)	6,901 kJ/kWh (6,541 Btu/kWh)
Number of gas turbines	1	2
Pressure/reheat	Dual/No	Dual/No

The SGT6-2000E gas turbine is a proven, robust engine for the 60 Hz market which is used in simple cycle or combined cycle processes with or without combined heat and power supply. It is suitable for all load ranges, including peak load.

# SGT5-2000E Heavy-duty gas turbine

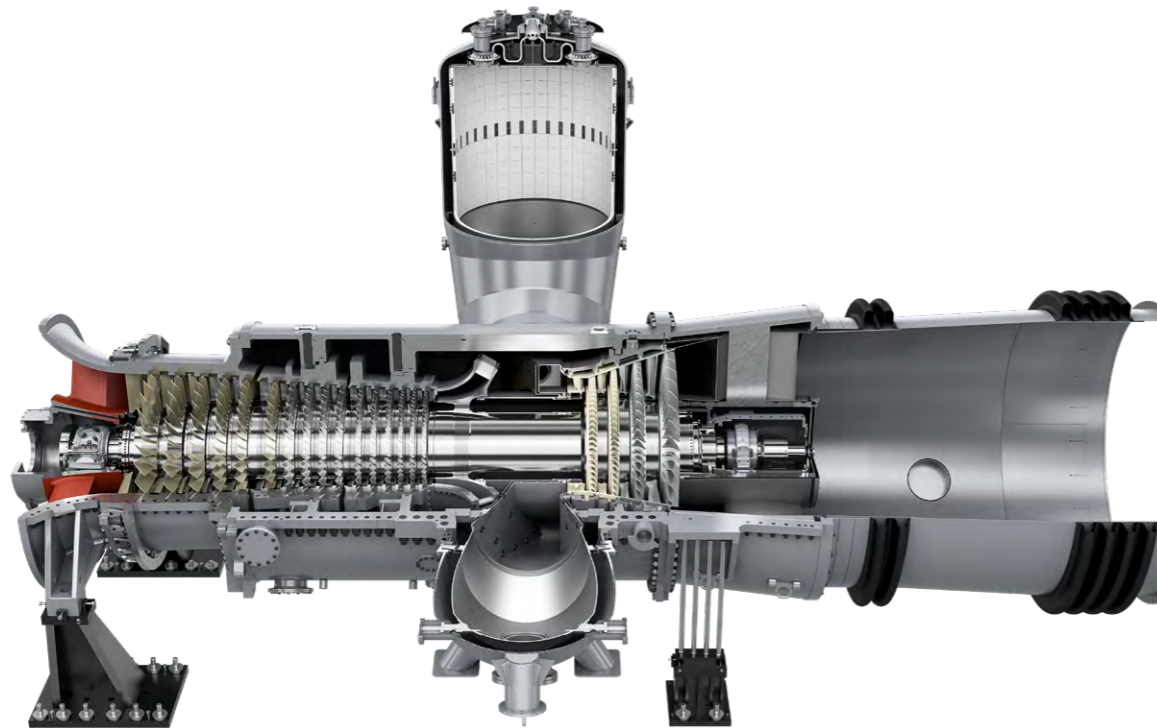

The SGT5-2000E gas turbine is a proven, robust engine for the 50 Hz market which is used in simple cycle or combined cycle processes with or without combined heat and power. It is suitable for all load ranges, including peak load.

Performance data for combined cycle power plant

	SCC5-2000E 1 × 1	SCC5-2000E 2 × 1
Gross power output	290 MW	581 MW
Gross plant efficiency	55.6%	55.9%
Gross heat rate	6,474 kJ/kWh (6,136 Btu/kWh)	6,440 kJ/kWh (6,104 Btu/kWh)
Number of gas turbines	1	2
Pressure/reheat	Dual/No	Dual/No

All combined cycle performance is based on 2 pressure, no reheat.

# SCC6-5000F Heavy-duty gas turbine

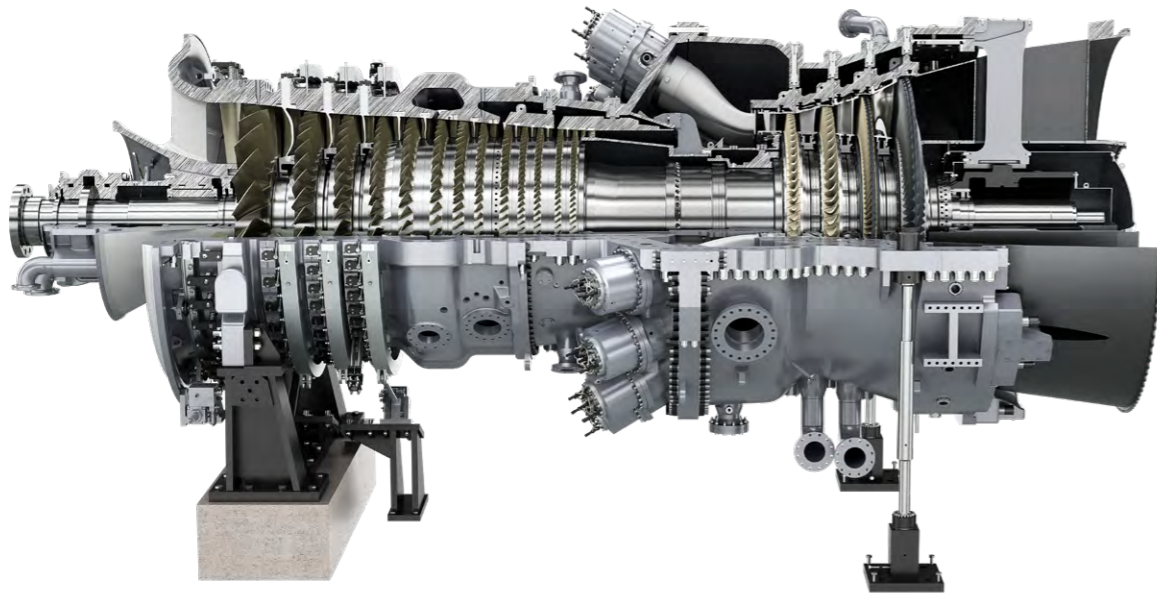

The SGT6-5000F gas turbine offers economical power generation with fast start-up for peak, intermediate, or base load duty. It achieves peak values for reliability and continuous operation with highest performance values in its class.

## Performance data for 2 × 1 combined cycle power plant

	<b>260 MW version</b>
Gross plant power output	391 MW(e)
Gross plant efficiency	60.5%
Gross heat rate	5,950 kJ/kWh (5,640 Btu/kWh)
Number of gas turbines	1
Pressure/reheat	Triple/Yes

## Performance data for 2 × 1 combined cycle power plant

	<b>260 MW version</b>
Gross plant power output	790 MW(e)
Gross plant efficiency	60.7%
Gross heat rate	5,930 kJ/kWh (5,621 Btu/kWh)
Pressure/reheat	Triple/Yes

# SCC5-4000F Heavy-duty gas turbine

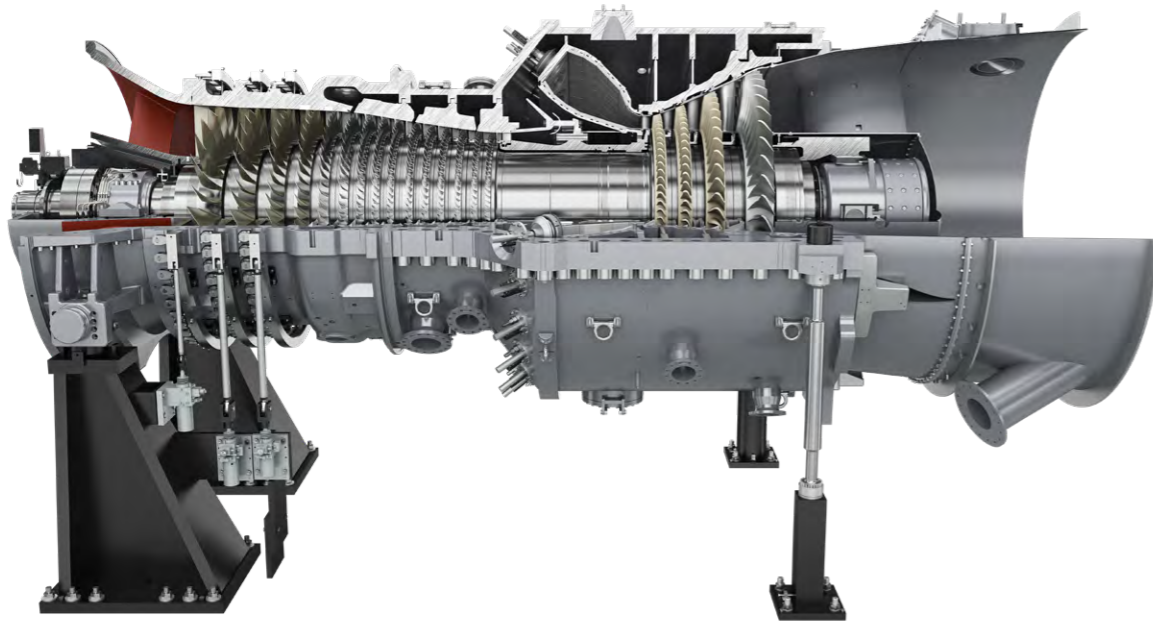

The proven SGT5-4000F gas turbine has a robust design with internal cooling air passages for trusted long-term operation and fast start-up capability. The advanced annular combustion chamber with individually replaceable heat shields allows for easy and fast walk-in maintenance.

Hydraulic Clearance Optimization (HCO) reduces clearance losses to increase the gas turbine efficiency and minimize degradation at start-up and shut down.

## Performance data for 1 × 1 combined cycle power plant

	329 MW version	385 MW version
Gross plant power output	485 MW	570 MW
Gross plant efficiency	61.0%	62.0%
Gross heat rate	5,900 kJ/kWh (5,592 Btu/kWh)	5,807 kJ/kWh (5,503 Btu/kWh)
Number of gas turbines	1	1
Pressure/reheat	Triple/Yes	Triple/Yes

## Performance data for 2 × 1 combined cycle power plant

	329 MW version	385 MW version
Gross power output	970 MW	1140 MW
Gross plant efficiency	61.0%	62.0%
Gross heat rate	5,900 kJ/kWh (5,592 Btu/kWh)	5,807 kJ/kWh (5,503 Btu/kWh)
Number of gas turbines	2	2
Pressure/reheat	Triple/Yes	Triple/Yes

# SGT6-8000H Heavy-duty gas turbine

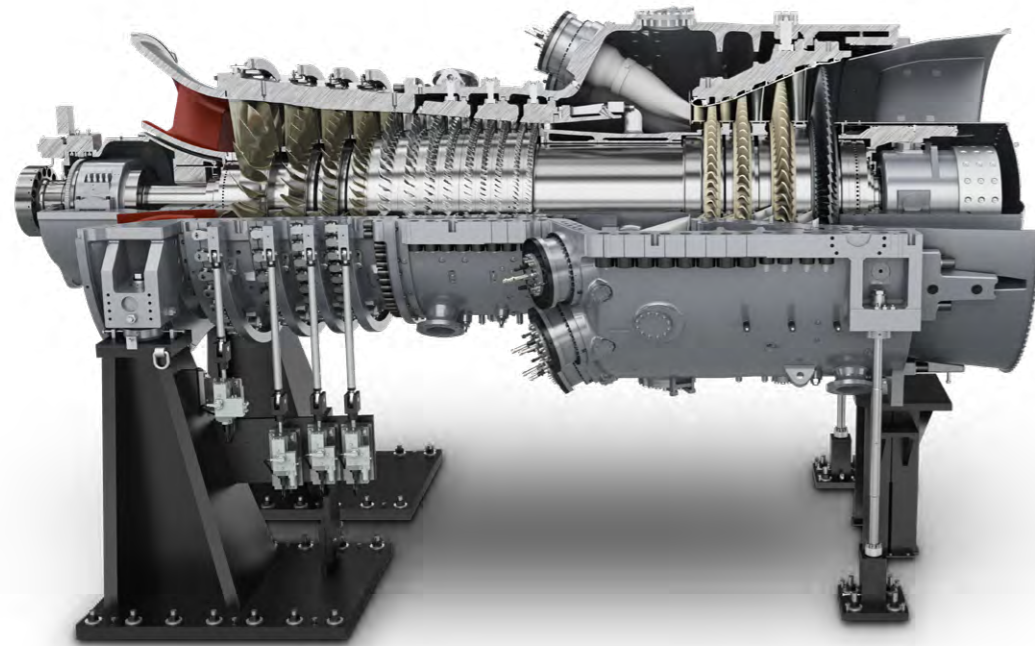

Performance data for combined cycle power plant

	SCC6-8000H 1S/1 × 1	SCC6-8000H 2 × 1
Gross power output	472 MW	948 MW
Gross plant efficiency	61.9%	62.1%
Gross heat rate	5,815 kJ/kWh (5,512 Btu/kWh)	5,795 kJ/kWh (5,493 Btu/kWh)
Number of gas turbines	1	2
Pressure/reheat	Triple/Yes	Triple/Yes

The SGT6-8000H offers outstanding performance and high operational flexibility. The air-cooled turbine provides a power output of 310 MW. With short start-up times and high load variations, the turbine offers low life-cycle costs and helps to meet fluctuating power demands.

# SCC5-8000H Heavy-duty gas turbine

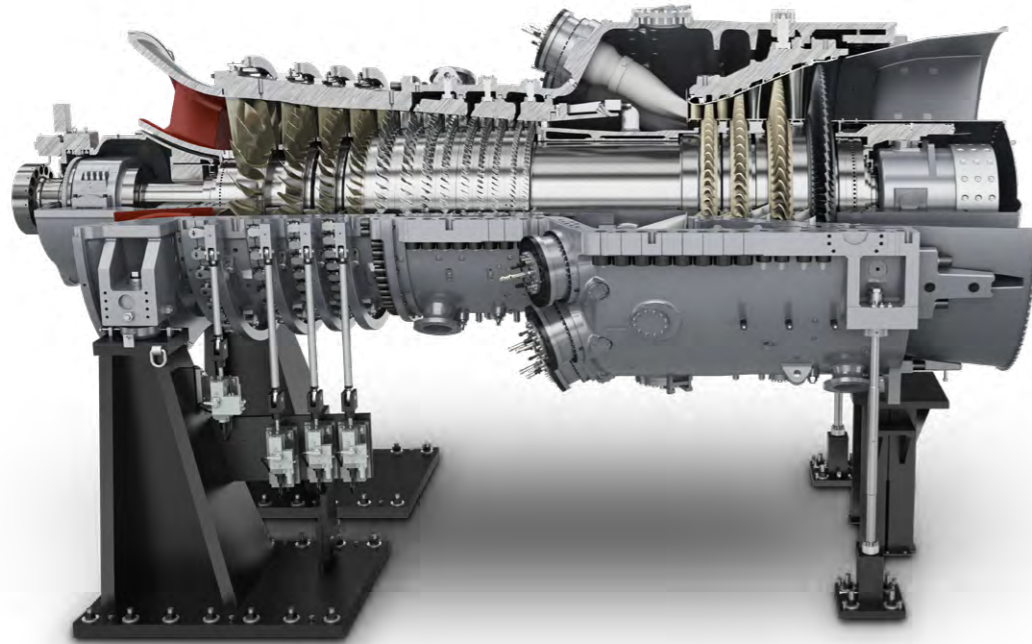

Performance data for combined cycle power plant

	SGT5-8000H CC 1 × 1/1S	SGT5-8000H CC 2 × 1
Frequency	50 Hz	50 Hz
Gross plant power output	675 MW	1,350 MW
Gross plant efficiency	62.4%	62.4%
Gross heat rate	5,770 kJ/kWh (5,469 Btu/kWh)	5,770 kJ/kWh (5,469 Btu/kWh)
Number of gas turbines	1	2
Pressure/reheat	Triple/Yes	Triple/Yes
Steam temperature	> 600°C (> 1,112°F)	> 600°C (> 1,112°F)

The SGT5-8000H offers outstanding performance and high operational flexibility. The air-cooled turbine provides a power output of 450 MW. With short start-up times and high load variations, the turbine offers low lifecycle costs and helps to meet fluctuating power demands.

# SGT6-9000HL Heavy-duty gas turbine

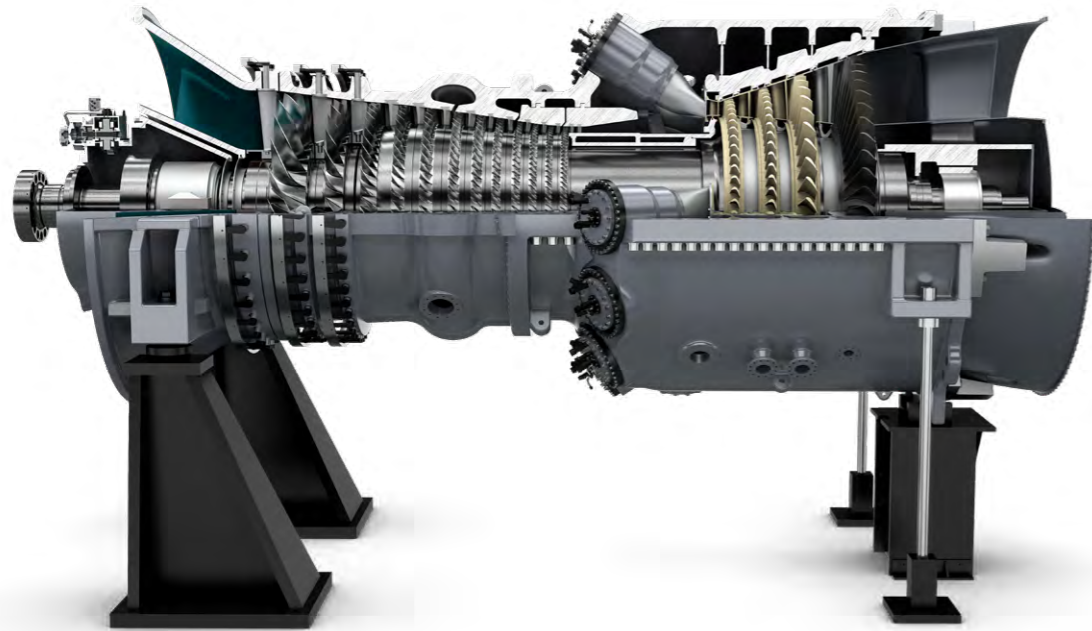

Siemens Energy HL-class gas turbines are paving the way to the next level of efficiency and performance. The evolutionary development step, derived from proven H-class technology, combines a series of new but already tested technologies like super-efficient internal cooling features for blades and vanes and an advanced combustion system to increase firing temperature. Record-holder for the most powerful and efficient combined cycle efficiency exceeding 64%.

Performance data for combined cycle power plant

	SGT6-9000HL CC 1 × 1 / 1S	SGT6-9000HL CC 2 × 1
Frequency	60 Hz	60 Hz
Gross plant output	655 MW	1,310 MW
Gross plant efficiency	> 64%	> 64%
Plant turn down	< 40%	< 40%
Gross heat rate	< 5,625 kJ/kWh (< 5,331 Btu/kWh)	< 5,625 kJ/kWh (< 5,331 Btu/kWh)
Number of gas turbines	1	2
Pressure/reheat	Triple/Yes	Triple/Yes
Steam temperature	> 600 °C (> 1,112 °F)	> 600 °C (> 1,112 °F)

Combined cycle ratings are gross at ISO conditions natural gas fuel.  
Actual ratings will vary with project specific conditions and fuel.

# SGT5-9000HL Heavy-duty gas turbine

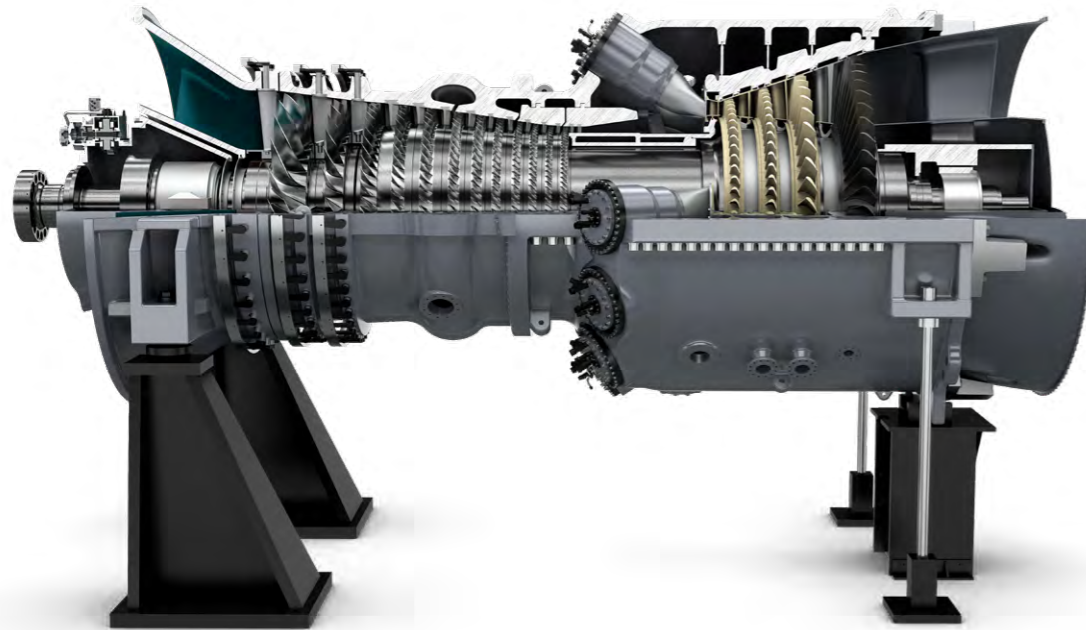

Performance data for combined cycle power plant

	SGT5-9000HL CC 1 × 1 / 1S	SGT6-9000HL CC 2 × 1
Frequency	50 Hz	50 Hz
Gross plant output	880 MW	1,760 MW
Gross plant efficiency	> 64%	> 64%
Plant turn down	< 40%	< 40%
Gross heat rate	< 5,625 kJ/kWh (< 5,331 Btu/kWh)	< 5,625 kJ/kWh (< 5,331 Btu/kWh)
Number of gas turbines	1	2
Pressure/reheat	Triple/Yes	Triple/Yes
Steam temperature	> 600 °C (> 1,112 °F)	> 600 °C (> 1,112 °F)

Siemens Energy HL-class gas turbines are paving the way to the next level of efficiency and performance. The evolutionary development step, derived from proven H-class technology, combines a series of new but already tested technologies like super-efficient internal cooling features for blades and vanes and an advanced combustion system to increase firing temperature. Record-holder for the most powerful and efficient combined cycle efficiency exceeding 64%.

Combined cycle ratings are gross at ISO conditions natural gas fuel.  
Actual ratings will vary with project specific conditions and fuel.

For more information, please contact our  
Siemens Energy Customer Support Center

Phone: +49 180 524 70 00

Fax: +49 180 524 24 71

(Charges depending on provider)

E-mail: [gs.sales@siemens-energy.com](mailto:gs.sales@siemens-energy.com)

<https://www.siemens-energy.com/gasturbines>

© Siemens Energy 2025

Subject to changes and errors. The information given in this document only contains general descriptions and/or performance features which may not always specifically reflect those described, or which may undergo modification in the course of further development of the products. The requested performance features are binding only when they are expressly agreed upon in the concluded contract.

Siemens Energy is a trademark licensed by Siemens AG.