



SIEMENS

Ingenuity for life



SGT-A45 mobile unit

Immediate power to the grid –
highest power density, trusted technology

Based on proven aeroderivative gas turbine technology, the SGT-A45 mobile unit is an outstanding solution for fast power. With up to 44 MW of electrical output, it offers significantly more power and higher fuel efficiency than any other mobile gas turbine.

Features

- The world's most powerful mobile gas turbine (up to 44 MWe)
- Fast deployment solution for urgent power needs
- Trailer-mounted modules with few, fast interconnections
- Each unit precommissioned and tested at the factory
- Core engine modules from SGT-A65 (Industrial Trent 60) matched to a proven free power turbine
- Proven, highly efficient aeroderivative turbomachinery
- Compact footprint
- Uses liquid or gas fuel, with flexibility to switch over at any time in operation
- Optional water injection for low NO_x and instant power boost
- Dual-frequency package with simple configuration change
- Designed for integration in complete power solution
- Transportable by road, air, or sea

Benefits

- Mobile solution up to 44 MW(e), with outstanding power density
- Fast, flexible power on delivery with fewer units and lower \$/kW
- Site installation and commissioning in less than 2 weeks
- Fast start (8 minutes or less) and flexible operation
- Easy transport to site and relocation
- High fuel efficiency
- Performance optimized for hot climates
- Dual-fuel flexibility (liquid and gas)
- Low-NO_x option
- Layout and installation optimized for full power plant solution
- Same maintenance interval on gas and liquid fuel
- Restart at any time – no “hot lockout” or “hot standby”

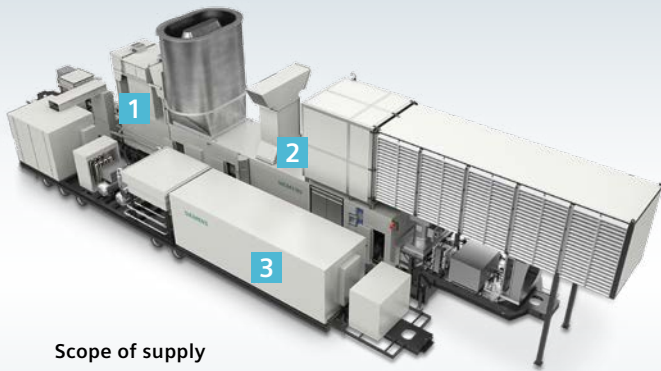

Scope of supply

Trailer 1

- A/C generator
- Generator lubrication and cooling systems

Trailer 2

- Gas turbine
- Gas turbine ancillary systems (fuel, lube oil, etc.)

Trailer 3

- Unit control system
- Motor control center
- Switchgear

Air inlet and filter and exhaust stack designed for simple and quick installation on unit at site.

Mobile unit

- Up to 44 MW(e) (ISO)
- 50 Hz or 60 Hz
- Liquid and gas fuel
- Emissions to < 25 vppm NO_x
- Mounted on trailers
- Highly standardized

Optional balance of plant scope

- Generator step-up transformers
- Liquid fuel storage and treatment
- Water demineralization plant
- Natural gas compressors and filters

Siemens can supply the required scope of Balance of Plant (BoP) equipment, integration services, or complete power solution. Financing options available.

Specification	50 Hz		60 Hz	
	15° C	30° C	15° C	30° C
Electrical power (ISO, dry)	41.0 MW(e)	39.3 MW(e)	44.0 MW(e)	39.6 MW(e)
Electrical efficiency (ISO, dry)	39.0%	38.4%	40.4%	39.5%
Fuel type	Dual (gas & liquid)			
Low emissions option	Water injection			
Low emissions – gas fuel	25 vppm NO _x			
Low emissions – liquid fuel	42 vppm NO _x			
Turbine speed	3,000 rpm		3,600 rpm	
Pressure ratio	27.7 : 1	26.7 : 1	27.9 : 1	25.8 : 1
Exhaust gas flow	127 kg/s	120 kg/s	126 kg/s	116 kg/s
Exhaust gas temperature	477° C	501° C	483° C	498° C

Published by
Siemens AG 2018

Power and Gas Division
Distributed Generation
Freyeslebenstrasse 1
91058 Erlangen, Germany

Article No. PGDG-T10034-02-7600

Printed in Germany

Dispo 34806

TH 566-180083 FS 0218

Subject to changes and errors.

The information given in this document only contains general descriptions and/or performance features which may not always specifically reflect those described, or which may undergo modification in the course of further development of the products.

Note: Nominal performance shown.

Performance guarantees are only provided in individual project proposals based on specifications given. Nominal performance shown referred to sea level, 60% relative humidity, natural gas fuel, zero installation losses.

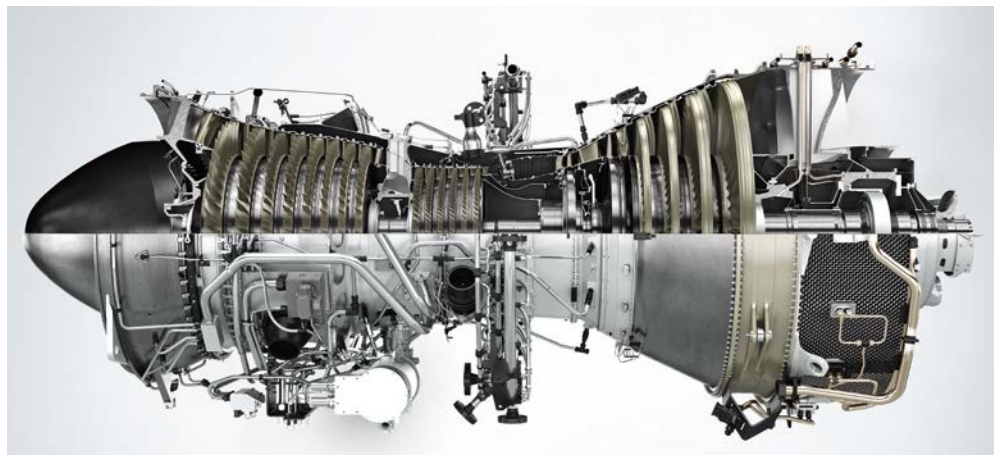

45 MW class core engine derived from the SGT-A65 (Industrial Trent 60)